

PLAN

NOTES:

1. THIS ARRANGEMENT IS INTENDED FOR RURAL LOW DENSITY RESIDENTIAL ACCESS WAYS.
2. COUNCIL RESERVES THE RIGHT TO DIRECT THE USE OF CULVERT END WALL TYPE.
3. THIS IS A TYPICAL CROSSING PLAN. SLIGHT VARIATIONS MAY OCCUR AFTER INSPECTION AND APPROVAL OF LOCATION BY COUNCIL.
4. PRIOR TO THE CONSTRUCTION, THE CROSSING LOCATION SHALL BE APPROVED BY COUNCIL.
5. ALL WORKS TO BE COMPLETED TO THE SATISFACTION OF COUNCIL.
6. MAINTENANCE OF THE CROSSOVER REMAINS THE RESPONSIBILITY OF THE LAND OWNER.
7. DRIVEABLE ENDWALLS TO BE USED WITHIN 1.5m OF THE EDGE OF SEAL
8. TABLE DRAINS ARE NOT TO BE CLOSER THAN 1.0m FROM FENCE LINES OR SERVICES.
9. CULVERT TO BE LOCATED AT LEAST 600mm FROM EDGE OF SEAL

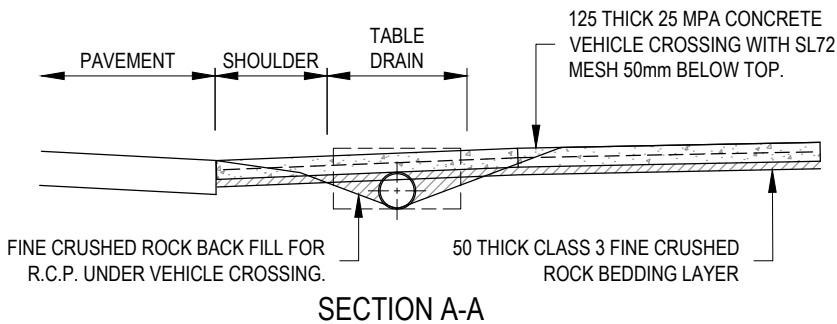

ALL MEASUREMENTS IN MILLIMETRES

**TYPICAL SWALE DRAIN VEHICLE CROSSING
(FRINGE URBAN RESIDENTIAL ENTRANCE)**

LAST UPDATED 06/02/2019

Infrastructure Design Manual Standard Drawings

A copy of the Infrastructure Design Manual can be viewed on the Design Manual website www.designmanual.com.au