



STRATHBOGIE SHIRE COUNCIL

Notice is hereby given that a Special Meeting of the Strathbogie Shire Council will be held on Tuesday 22 October 2013 at the Euroa Community Conference Centre commencing at 5.30 p.m.

Councillors: Debra Swan (Chair)
Colleen Furlanetto
Malcolm Little
Alister Purbrick
Patrick Storer
Robin Weatherald
Graeme (Mick) Williams

Officers: Steve Crawcour - Chief Executive Officer
Roy Hetherington - Director, Asset Services
David Woodhams – Director, Corporate and Community
Phil Howard – Director, Sustainable Development
Gary Abley – Manager, Organisational Development

BUSINESS

1. Welcome
2. Acknowledgement of Traditional Land Owners
'In keeping with the spirit of Reconciliation, we acknowledge the traditional custodians of the land on which we are meeting today. We recognise indigenous people, their elders past and present'.
3. Apologies
4. Disclosure of Interests

EXCERPT FROM MEETING PROCEDURE LOCAL LAW NO. 1

CONDUCT OF PUBLIC

52. VISITORS

- (1) Visitors must not interject or take part in debate.
- (2) Silence shall be preserved in the gallery at all times.
- (3) If any visitor is called to order by the Chairperson and again acts in breach of this Local Law, the Chairperson may order that person to be removed from the gallery.

53. CALL TO ORDER

Any person who has been called to order, including any Councillor who fails to comply with the Chairperson's direction, will be guilty of an offence.
Penalty: \$500

54. *REMOVAL FOR DISRUPTION*

The Chairperson has discretion to cause the removal of any person, including a Councillor, who disrupts any meeting or fails to comply with a direction under the provisions of this Local Law.

- 5. Reports of Council Officers
 - 5.1 Climate Change
 - 5.2 Infrastructure
 - 5.3 Private Enterprise
 - 5.4 Public Institutions
 - 5.5 Housing and Recreation
 - 5.6 Tourism
 - 5.7 Organisation

Steve Crawcour
CHIEF EXECUTIVE OFFICER

15 October 2013

REPORTS INDEX

5.	REPORTS	
5.7	ORGANISATION	
5.7.1	2013-2017 Shire of Strathbogie Council Plan - First Quarter Report ~ 1 July to 30 September 2013	1
5.7.2	Consideration of Strathbogie Shire Council's Annual Report for the Year ended 30 June 2013	32
5.7.3	Council Policy Footpath Trading Policy	34
5.7.4	Council Policy Media Policy and Protocols	38
5.7.5	Council Policy Risk Management Policy	44
5.7.6	Council Policy Muted Tones Policy	52
5.7.7	Council Policy ICT Vendor Access Policy	54
5.7.8	Council Policies Review of Asset Services Policies	56
5.7.9	Council Policies Review of Waste Management Policies	119
5.7.10	Documents for Signing and Sealing	137

5. **REPORTS**

5.7 **ORGANISATION**

5.7.1 **2013-2017 Shire of Strathbogie Council Plan** **- First Quarter Report ~ 1 July to 30 September 2013**

Author & Department

Director, Corporate and Community / Corporate and Community Directorate

Disclosure of Conflicts of Interest in relation to advice provided in this report

Officers providing advice in relation to this report do not have a direct or indirect interest, as provided in accordance with the *Local Government Act 1989*.

Summary

The 2013-2017 Shire of Strathbogie Council Plan was adopted by Council at a Special Council meeting held on Wednesday 16 June 2013.

The 2013-2017 Shire of Strathbogie Council Plan has, in summary:

A total of 114 Actions -

- > *Goal 1 - Community Wellbeing ~ 20 Actions*
- > *Goal 2 - Environment ~ 17 Actions*
- > *Goal 3 - Financial ~ 14 Actions*
- > *Goal 4 - Governance ~ 7 Actions*
- > *Goal 5 - Industry, Business and Investment ~ 10 Actions*
- > *Goal 6 - Infrastructure ~ 38 Actions*
- > *Goal 7 - Tourism and Hospitality ~ 8 Actions*

- 32 Actions are listed for commencement and completion in 2013-2014
- 15 Actions are listed for commencement and completion in 2014-2015
- 1 Action is listed for commencement and completion in 2015-2016
- 18 Actions are listed for commencement and completion in the period 2013-2015
- 4 Actions are listed for commencement and completion in the period 2013-2016
- 2 Actions are listed for commencement and completion in the period 2014-2016
- 42 Actions are spread out over the life of the Council Plan (2013-2017), with completion by June 2017

Quarterly reports are presented to Council to provide an update on the status of the Actions. The Actions of the Plan have been reviewed and progress updated, and details are provided in the attached report.

There are 96 actions which are to commence in the 2013/2014 period which have, in this quarter, either been 'Completed', 'Not Started', or are 'In Progress'.

5.7.1 2013-2017 Shire of Strathbogie Council Plan
- First Quarter Report ~ 1 July to 30 September 2013 (cont.)

RECOMMENDATION

That the report be noted.

Background

Council is required to prepare a Council Plan every four years with the actions within that plan changing yearly in accordance with section 125 of the *Local Government Act 1989*. The Council Plan includes the strategic objectives of Council and actions for achieving those objectives. The Council Plan is prepared in conjunction with the yearly budget to ensure cost implications are considered and accounted for.

This report is for the first quarter (July – September 2013) of the 2013-2017 Council Plan.

Alternative Options

Officers providing advice in relation to this report have considered potential alternative courses of action. No feasible alternatives have been identified.

Risk Management

The author of this report considers that there are no significant Risk Management factors relating to the report and recommendation.

Strategic Links – policy implications and relevance to Council Plan

The author of this report considers that the report is consistent with Council Policies, key strategic documents and the Council Plan.

Best Value / National Competition Policy (NCP) / Competition and Consumer Act 2010 (CCA) implications

The author of this report considers that the report is consistent with Best Value, National Competition Policy and Competition and Consumer Act requirements.

Financial / Budgetary Implications

All Council Plan actions are considered during the budget process at the start of the financial year.

Economic Implications

The author of this report considers that the recommendation has no significant economic implications for Council or the broader community.

Environmental / Amenity Implications

The author of this report considers that the recommendation has no significant environmental or amenity implications for Council or the broader community.

5.7.1 2013-2017 Shire of Strathbogie Council Plan
- First Quarter Report ~ 1 July to 30 September 2013 (cont.)

Community Implications

The author of this report considers that the recommendation has no significant community or social implications for Council or the broader community.

Victorian Charter of Human Rights and Responsibilities Act 2006

The author of this report considers that the recommendation does not limit any human rights under the Victorian Charter of Human Rights and Responsibilities Act 2006.

Legal / Statutory Implications

The author of this report considers that the recommendation has no legal or statutory implications which require the consideration of Council.

Consultation

The author of this report considers that the matter under consideration did not warrant a community consultation process.

Attachments

Strathbogie Shire Council Plan Progress Report for the July to September 2013 quarter.



2013-2017 COUNCIL PLAN PROGRESS REPORT

Status Indicators Key:

-  In Progress
-  Not Started
-  Completed
-  Under Review

Created: 15 October 2013

GOAL: 1 A community that has equitable access to a range of quality services which respond to its diverse needs and supports the wellbeing of our communities (Community Wellbeing)

OBJECTIVE: 1.1. Plan, support and / or deliver a broad range of responsive and accessible services to our diverse community

STRATEGY: 1.1.1. Enhance the wellbeing and participation of our community

ACTION: 1.1.1.01. Continue to support and participate in the Strathbogie Health and Community Services Consortium

Position(s)	Target Date	% Complete	Status	Comments
Chief Executive Officer	30-Jun-2014	25%		First meeting for the 2013 /14 Year was conducted on the 2nd August 2013.

ACTION: 1.1.1.02. As part of Council's Health and Wellbeing Plan identify ways to promote shire-wide health and wellbeing

Position(s)	Target Date	% Complete	Status	Comments
Manager Community Development	30-Jun-2014	10%		council's health and wellbeing plan identifies key strategies and actions to promote shire wide health and wellbeing; the plan has been reviewed and is awaiting council approval and will form the basis for council support for health promotion over the coming four years

ACTION: 1.1.1.03. Investigate the formation of a Youth Council and seek funding

Position(s)	Target Date	% Complete	Status	Comments
Manager Community Development	30-Jun-2014	10%		The formation of a Youth Council is under investigation. Funding has not yet been identified. This action is also reflected in the Youth Strategy which is in draft form currently.

ACTION: 1.1.1.04. Reintroduce a shire-wide Disability Advisory Committee

Position(s)	Target Date	% Complete	Status	Comments
Manager Community Development	30-Jun-2014	65%		The preparation work for a renewed Disability Advisory Committee has been completed. The final work to recruit for the committee and set out the terms and conditions and other governance arrangements is underway. The committee is expected to meet for the first time by early November 2013.

ACTION: 1.1.1.05. Support Community Action Groups to develop methods of improved communication during emergencies

Position(s)	Target Date	% Complete	Status	Comments
Manager Community Development	30-Jun-2014	5%		The Community Development Officer has met with Strathbogie Tablelands Action Group to discuss funding application for housing of generator for NSP;

ACTION: 1.1.1.06. Advocate that every child should have a competent learn to swim opportunity

Position(s)	Target Date	% Complete	Status	Comments
Manager Community Development	30-Jun-2014	%		Write to all schools within the Strathbogie Shire requesting they consider including swimming lessons for all children as part of their curriculum.

ACTION: 1.1.1.07. Collaborate and provide support to the development of Community Action Group Action Plans

Position(s)	Target Date	% Complete	Status	Comments
Manager Community Development	30-Jun-2014	20%		The Community Action Group guidelines have been updated; the Community Development Officer has attended the Action Group AGMs; the Action Group plans are being reviewed and developed with support from the Community Development Officer; the action group plan grants have been allocated for 2013/14

ACTION: 1.1.1.08. Support the "Prevention of Violence Against Women and Children Supporting Safer Communities" Action Plan

Position(s)	Target Date	% Complete	Status	Comments
Manager Community Development	30-Jun-2014	20%		The Community Development Officer and Cr Furlanetto are members of the Steering Committee for this project, and also members of the Local Government Sub-Committee for this project. The sub committee is focussing on producing the outcomes for actions identified in the plan, through collaboration between local government departments across the Hume Region.

ACTION: 1.1.1.09. Review and improve the Community Engagement Plan

Position(s)	Target Date	% Complete	Status	Comments
Manager Communications	30-Jun-2014	20%		Community engagement survey has been developed in both paper and online versions. Dates for surveying to take place have been established to occur from October to November. Environmental scan is currently being conducted and once the surveying is complete the draft Community Engagement Model can be developed.

ACTION: 1.1.1.10. Investigate opportunities for shire-wide youth cultural activities

Position(s)	Target Date	% Complete	Status	Comments
Manager Community Development	30-Jun-2014	25%		The Youth Engage and Youth FReeZA action plans have been submitted to the Department of Human Services in line with funding requirements. Each of these funded programs provides cultural activities across the Shire. Activities so far completed include the Battle of the Bands; Art Gallery workshop (cyber bullying); youth committee in Euroa is underway - plans for Nagambie, Avenel and Violet Town are included in future activities in the coming three year period of the funding; three themed movie nights; sound crew at local markets. Buses are provided for young people who live in outlying towns.

ACTION: 1.1.1.11. Design in consultation with VicRoads a suitable drop off / pick up area in Anderson Street, Euroa (Euroa Primary School)

Position(s)	Target Date	% Complete	Status	Comments
Manager Engineering	31-Dec-2013	50%		Met with Principal of school. Explained purpose of survey and design. Engaged consultants to undertake work. They have the design 50% complete.

ACTION: 1.1.1.12. Work with Euroa Rotary / Euroa Citizens Band to design and construct a sound shell at Euroa Band Hall

Position(s)	Target Date	% Complete	Status	Comments
Director Asset Services	28-Feb-2014	25%		Prepared a concept plan in consultation with the Rotary Club. Rotary Club in discussions with the Band Hall.

ACTION: 1.1.1.13. Support the development of a men's shed program across the shire.

Position(s)	Target Date	% Complete	Status	Comments
Manager Community Development	30-Jun-2014	25%		The Community Development Officer has met with the committee of the mens' shed at Nagambie to look at funding requirements and support required to have a shed up and running in Nagambie. The community at Ruffy have shown interest also in a men's shed. Advice to Nagambie on governance has been provided. Executive, CDO and council staff have met with the Nagambie group to offer a suitable site for the building. The Euroa and Violet Town men's sheds are in place already. CDO has provided advice on funding to VT Men's Shed in relation to all accessible toilet; and separate funding for defibrillator.

STRATEGY: 1.1.2. Increase community services to Nagambie post bypass

ACTION: 1.1.2.01. Advocate for a full time child care facility in Nagambie

Position(s)	Target Date	% Complete	Status	Comments
Manager Community Development	30-Jun-2014	%		At present, need to determine demand levels for child care in Nagambie

ACTION: 1.1.2.02. Advocate for funding of Nagambie Lakes Community House

Position(s)	Target Date	% Complete	Status	Comments
Manager Community Development	30-Jun-2014	20%		Community Development Officer has met with the Department of Human Services representative and the Nagambie Lakes Community House to discuss funding options. Some funding has been received by the House from a volunteer grant to support purchase of data projector and screen. Continued discussions and meetings with DHS representative is required to secure ongoing funding. At this stage the group is not eligible.

ACTION: 1.1.2.03. Advocate for an ambulance service based in Nagambie

Position(s)	Target Date	% Complete	Status	Comments
Manager Community Development	30-Jun-2014	%		Letter to Ambulance Vic/State Government to be sent. Ambulance Vic advised in 2010/11 that Nagambie is on a priority list of towns for a station.

ACTION: 1.1.2.04. Advocate for a high school in Nagambie

Position(s)	Target Date	% Complete	Status	Comments
Manager Community Development	30-Jun-2014	%		There is a need to determine the demand and population data to support this advocacy

STRATEGY: 1.1.3. Provide equitable and high standard public transport services / facilities

ACTION: 1.1.3.01. Advocate for improved train station facilities across the shire

Position(s)	Target Date	% Complete	Status	Comments
Chief Executive Officer	30-Jun-2014	50%		Raised at North East Local Government Meeting and the Goulburn Valley Mayors and CEO's Meeting. It has also been raised at a joint meeting of the Goulburn Valley River Tourism as an inhibitor to Tourism activities.

ACTION: 1.1.3.02. Advocate for better time-tabling and shuttle services between Shepparton to Seymour and Wodonga to Seymour

Position(s)	Target Date	% Complete	Status	Comments
Chief Executive Officer	30-Jun-2014	50%		Raised at North East Local Government Meeting and the Goulburn Valley Mayors and CEO's Meeting. It has also been raised at a joint meeting of the Goulburn Valley River Tourism as an inhibitor to Tourism activities.

GOAL: 2 To promote and foster sustainable development in our natural and built environment (Environment)

OBJECTIVE: 2.1. To continue to protect and enhance the natural and built environment for current and future generations

STRATEGY: 2.1.1. Encourage clean, green environmental initiatives

ACTION: 2.1.1.01. Work with GBCMA to review flood mitigation requirements for residential buildings in Euroa and surrounds with the ability to release land for residential use

Position(s)	Target Date	% Complete	Status	Comments
Director Asset Services	30-Jun-2014	50%		Euroa Township Flood remodelling underway.

ACTION: 2.1.1.02. Consult with GMW to improve and boost water storage facilities on the Seven Creeks

Position(s)	Target Date	% Complete	Status	Comments
Director Asset Services	30-Jun-2014	25%		Options for improvement identified in GVW's Masterplan.

ACTION: 2.1.1.03. Establish a Shire-wide Sustainable Development Reference Group

Position(s)	Target Date	% Complete	Status	Comments
Director Sustainable Development	30-Nov-2013	10%		Terms of reference drafted.

ACTION: 2.1.1.04. Continue to develop the Violet Town flood mitigation scheme

Position(s)	Target Date	% Complete	Status	Comments
Manager Projects & Works	30-Jun-2014	50%		Council is investigating alternative options for the scheme to reduce the number of houses to be raised due to the difficulty in getting the consent of some of the house owners.

ACTION: 2.1.1.05. Introduce an Organic Household Waste Service

Position(s)	Target Date	% Complete	Status	Comments
Manager Projects & Works	31-Jan-2014	100%		Council has put a hold on this project after community consultation results showed that the community was not ready for the scheme. Council will reconsider the proposal when a new waste contract is being investigated.

ACTION: 2.1.1.06. Provide a secure water supply to the Euroa Showgrounds

Position(s)	Target Date	% Complete	Status	Comments
Director Asset Services	30-Jun-2014	%		Project deleted from 13/14 budget. To be referred to the 14/15 Budget.

ACTION: 2.1.1.07. Participate in Regional Street Lighting Retro-Fit Program

Position(s)	Target Date	% Complete	Status	Comments
Manager Projects & Works	30-Jun-2014	10%		Council has obtained Government funding for the project and is working with other Council's in the region to let the contract.

ACTION: 2.1.1.08. Complete the Violet Town Landfill capping project

Position(s)	Target Date	% Complete	Status	Comments
Manager Projects & Works	30-Jun-2014	30%		Council has received verbal confirmation from EPA regarding the reclassification of the landfill to a 'Type 3' landfill. This will enable Council to utilise the existing desing with minimum modification.

STRATEGY: 2.1.2. Develop, maintain and protect our natural and built assets

ACTION: 2.1.2.01. Support Violet Town Action Group in preparation of a master plan for the Violet Town Recreation Reserve area

Position(s)	Target Date	% Complete	Status	Comments
Manager Community Development	30-Jun-2014	10%		The Community Development Officer has been in contact with the Violet Town Action Group; information provided to VTAG about the process involved in the development of the master plan; attended the VTAG AGM; discussed VTAG contribution to the cost of the master plan

ACTION: 2.1.2.02. Support the Euroa Environment Group to develop a Shire-wide Significant Tree Register on public land

Position(s)	Target Date	% Complete	Status	Comments
Director Asset Services	30-Jun-2014	%		Meeting with group planned for October.

ACTION: 2.1.2.03. Update Council's Tree Management Plan

Position(s)	Target Date	% Complete	Status	Comments
Director Asset Services	30-Jun-2014	25%		Working party convened in Violet Town to prioritise projects and assist in community consultation.

ACTION: 2.1.2.04. Support the actions in the Shire's Community Safety Fire Action Plan

Position(s)	Target Date	% Complete	Status	Comments
Director Asset Services	30-Jun-2014	70%		A number of projects fully completed and the remainder are underway.

ACTION: 2.1.2.05. Work with the "Bush Crew" where possible as part of the Shire's revegetation programs

Position(s)	Target Date	% Complete	Status	Comments
Manager Projects & Works	30-Jun-2014	50%		Council uses the Bush Crew on projects wherever this is possible.

ACTION: 2.1.2.06. Investigation cost neutral funding options for the employment of an Environment / Planning / Sustainable Development Officer once an industry standard position description is developed and costed

Position(s)	Target Date	% Complete	Status	Comments
Director Sustainable Development	30-Jun-2014	10%		Commencement of new Team Leader Planning on 7 Oct 2013. Will investigate the needs and funding opportunities as part of role.

GOAL: 3 To ensure prudent, transparent and strategic financial planning which results in a sound legacy for the future (Financial)

OBJECTIVE: 3.1. Provide best practice management and administrative systems and structures to support the delivery of Council services and programs

STRATEGY: 3.1.1. Rationalise Council owned assets

ACTION: 3.1.1.01. Sell the Euroa Youth Club Hall and relocate current use to a suitable location

Position(s)	Target Date	% Complete	Status	Comments
Director Asset Services	30-Jun-2014	%		Project to proceed upon completion of Little Theatre relocation.

ACTION: 3.1.1.02. Relocate Nagambie Shire Depot to Industrial Estate

Position(s)	Target Date	% Complete	Status	Comments
Manager Projects & Works	31-Mar-2014	30%		Construction of the new depot offices is in progress.

ACTION: 3.1.1.03. Develop for residential use and sell Nagambie Shire Depot

Position(s)	Target Date	% Complete	Status	Comments
Director Asset Services	30-Jun-2014	25%		Depot relocation nearing completion. Environmental works underway.

ACTION: 3.1.1.04. Investigate and determine underutilised assets within the Shire

Position(s)	Target Date	% Complete	Status	Comments
Director Asset Services	30-Jun-2014	25%		Asset registry is being examined for opportunity.

STRATEGY: 3.1.2. Continue to focus on improving operational efficiencies by decreasing costs

ACTION: 3.1.2.01. Continue to drive the Shared Service Project with Shepparton and Moira Council's in an endeavour to reduce operating expenditure and ensure efficiencies of service

Position(s)	Target Date	% Complete	Status	Comments
Chief Executive Officer	30-Jun-2014	60%		Draft Business Plan, Draft Project Plan and Draft Strategic Alliance Agreement completed. A joint meeting of the partnership CEO's and Executive Team will be conducted in October followed by a Briefing to Councillors at a later date.

ACTION: 3.1.2.02. Target major Capital Works Projects to seek government funding to reduce Council's costs

Position(s)	Target Date	% Complete	Status	Comments
Director Asset Services	30-Jun-2014	25%		Funding secured for Violet Town pedestrian link and fire access roads. Discussions commenced with VicRoads in relation to Nagambie main street.

ACTION: 3.1.2.03. Explore and take up partnership opportunities of non-core services with other Shires and Organisations

Position(s)	Target Date	% Complete	Status	Comments
Chief Executive Officer	30-Jun-2014	50%		Currently conducting joint services with other Council's. The latest Service will be delaying the Waste Services Tender to align with our neighbouring Councils so a joint Tender can be conducted late 2014.

ACTION: 3.1.2.04. Benchmark Business Units under the Best Value Legislation to ensure efficient, effective and relevant services are provided

Position(s)	Target Date	% Complete	Status	Comments
Director Corporate and Community	30-Jun-2014	%		Start January 2014

ACTION: 3.1.2.05. Review Council's Long Term Financial Plan and Rating Strategy

Position(s)	Target Date	% Complete	Status	Comments
Director Corporate and Community	31-Oct-2013	10%		Council has organised a Sustainability workshop 29th October 2013

ACTION: 3.1.2.06. Reduce Council's infrastructure gap in a financially responsible manner as per Council's Long Term Financial Plan

Position(s)	Target Date	% Complete	Status	Comments
Director Corporate and Community	30-Jun-2014	30%		2013/2014 budget developed based on Asset Management Policy but reduced due to funding constraints

ACTION: 3.1.2.07. Seek grant funding opportunities wherever possible

Position(s)	Target Date	% Complete	Status	Comments
Director Sustainable Development	30-Jun-2014	100%		Grant officer investigates all new funding streams when they occur for Council's strategic projects etc as an ongoing task.

ACTION: 3.1.2.08. Conduct a cost benefit analysis for the following operations - Shire wide operated swimming pools / Euroa Saleyards / Nagambie Lakes / Regatta Centre / Boating safety (compliance) operations in Nagambie / Shire wide Youth Services / Open Space/Parks Management

Position(s)	Target Date	% Complete	Status	Comments
Director Corporate and Community	30-Jun-2014	%		Start January 2014

STRATEGY: 3.1.3. Ensure Council has equitable support financially from both Federal and State Governments

ACTION: 3.1.3.01. Advocate for Constitutional recognition of Local Government

Position(s)	Target Date	% Complete	Status	Comments
Chief Executive Officer	30-Jun-2014	100%		Due to the Calling of the Fderal Election early this did not proceed.

ACTION: 3.1.3.02. Advocate to both Federal and State Government to ensure that the current funding formulas provide equitable funds to Local Government

Position(s)	Target Date	% Complete	Status	Comments
Chief Executive Officer	30-Jun-2014	30%		Discussions held at North East Local Government Network and Hume RMF regarding the revised funding formulas and reduced support financially for Local Government.

GOAL: 4 A Shire that builds trust and recognises community needs through transparent, accountable and democratic decision making (Governance)

OBJECTIVE: 4.1. To provide all our stakeholders with consistent and timely decision making

STRATEGY: 4.1.1. Engage our community in our decision making processes

ACTION: 4.1.1.01. Develop a program that delivers increased Councillors interaction with the community in their local settings

Position(s)	Target Date	% Complete	Status	Comments
Manager Communications	30-Jun-2014	20%		Community engagement survey has been developed in both paper and online versions. Dates for surveying to take place have been established to occur from October to November. Environmental scan is currently being conducted and once the surveying is complete the draft Community Engagement Model can be developed.

ACTION: 4.1.1.02. Introduce an online system for improved community engagement

Position(s)	Target Date	% Complete	Status	Comments
Manager Communications	30-Nov-2013	50%		Community engagement survey has been developed in both paper and online versions. Dates for surveying to take place have been established to occur from October to November. Environmental scan is currently being conducted and once the surveying is complete the draft Community Engagement Model can be developed.

ACTION: 4.1.1.03. Review Council's Communication Strategy

Position(s)	Target Date	% Complete	Status	Comments
Manager Communications	30-Sep-2013	5%		Request for extension of time granted on 04/09/2013. The survey work for the community engagement model will assist in understanding as to what methods of communication will work for Council.

STRATEGY: 4.1.2. Provide a workforce that is accountable and transparent in its operations

ACTION: 4.1.2.01. Support gender equality in our workforce development

Position(s)	Target Date	% Complete	Status	Comments
Manager Organisation Development	30-Jun-2014	100%		Council Policies reviewed, Recruitment & Selection and Training & Development.

ACTION: 4.1.2.02. Address the actions required from the Internal Auditors reports and report back to Council via the Audit Committee

Position(s)	Target Date	% Complete	Status	Comments
Director Corporate and Community	30-Jun-2014	10%		Currently reviewing 2013/2014 audit results

ACTION: 4.1.2.03. Executive Management Team to monitor and review the ongoing performance of all staff operations

Position(s)	Target Date	% Complete	Status	Comments
Chief Executive Officer	30-Jun-2014	25%		This is discussed weekly at Executive Meetings and discussed quarterly at Audit Committee Meetings.

GOAL: 5 Encourage investment and development into the Shire by having a responsive and proactive business development culture (Industry, Business and Investment)

OBJECTIVE: 5.1. Pursue opportunities to increase the range of businesses and industries in the Shire to further strengthen our economy

STRATEGY: 5.1.1. Ensure Council has the ability to provide a single point of contact for its customers

ACTION: 5.1.1.01. Review the planning approval processes; staffing levels and operations for greater efficiencies

Position(s)	Target Date	% Complete	Status	Comments
Director Sustainable Development	30-Jun-2014	50%		New Team Leader Planning commencing 7 Oct 2013. Part of that role is to assist the Director in reviewing the other operational requirements for efficiency improvements.

ACTION: 5.1.1.02. Develop online and hard copy methods for self-service enquiry and resolution for planning applications

Position(s)	Target Date	% Complete	Status	Comments
Director Sustainable Development	31-Mar-2014	40%		Website updated for "Development" section.

ACTION: 5.1.1.03. Investigate a system to broaden Council's current Business Directory on the website to also include individual skill-based details

Position(s)	Target Date	% Complete	Status	Comments
Manager Economic Growth	30-Jun-2014	%		Waiting for update to website to be completed in relation to local businesses.

STRATEGY: 5.1.2. Support Nagambie traders post bypass

ACTION: 5.1.2.01. Develop a marketing / events campaign program

Position(s)	Target Date	% Complete	Status	Comments
Manager Communications	30-Jun-2014	40%		Love Strathbogie campaign in progress (launched at Regional Living Expo in April 2013)- online presence has been established and collateral has been printed (much of this was done for the Regional Living Expo). Logo is being made available for cross promotion and BEE is going to support this online. Euroa Gazette is supporting this on the front page regularly. Further work will be done in the future to increase the visibility of this marketing / tourism / events branding.

ACTION: 5.1.2.02. Establish a working group for strategic planning on branding, marketing and development of High Street retail area

Position(s)	Target Date	% Complete	Status	Comments
Manager Communications	30-Nov-2013	40%		Internal working group has been established between Communications and Economic Growth to promote the Love Strathbogie brand in all possible locations.

STRATEGY: 5.1.3. Support and enhance a 'Can-Do' culture

ACTION: 5.1.3.01. Conduct a Grants Forum / Expo on External Grants for all our community

Position(s)	Target Date	% Complete	Status	Comments
Manager Community Development	30-Jun-2014	%		Provide community action groups with advice on how to apply for external grants

ACTION: 5.1.3.02. Investigate the formation of an education alliance group around advocacy, information sharing, strategic partnership and economic development

Position(s)	Target Date	% Complete	Status	Comments
Manager Community Development	30-Jun-2014	%		Requires needs assessment

ACTION: 5.1.3.03. Develop and implement a change program focusing on a 'Can-Do' culture in business service

Position(s)	Target Date	% Complete	Status	Comments
Manager Economic Growth	30-Jun-2014	50%		In relation to development / business enquiries, there is a 'one stop shop' approach to assist new businesses through the approval processes.

ACTION: 5.1.3.04. Support development and investment with a commitment to fast efficient services to all customers

Position(s)	Target Date	% Complete	Status	Comments
Manager Customer Relations	30-Jun-2014	5%		Implementation of Planning software underway, integrating to the corporate Electronic Document Records Management System (EDRMS). Further enhancement and development of the EDRMS in relation to process and procedure clarification. Further research and investigation into customer request handling mobility and Asset maintenance mobility

ACTION: 5.1.3.05. Support actions in Council's Economic Development Master Plan

Position(s)	Target Date	% Complete	Status	Comments
Manager Economic Growth	30-Jun-2014	30%		Actions commenced in Economic Development Master Plan, e.g. implementation of the Municipal Strategic Statement.

GOAL: 6 Ensure the Shire's infrastructure enhances efficiency for people and freight movement, service delivery and community amenities (Infrastructure)

OBJECTIVE: 6.1. Provide well maintained, affordable and appropriate infrastructure

STRATEGY: 6.1.1. Provide industry standard facilities

ACTION: 6.1.1.01. Develop a Risk Management Plan for Euroa Saleyards

Position(s)	Target Date	% Complete	Status	Comments
Manager Projects & Works	30-Jun-2014	5%		This project is currently on hold awaiting the construction of the new roofed saleyard which will alter the risk profile of the facility.

ACTION: 6.1.1.02. Investigate options for the long term sustainability of the Euroa Saleyards including funding models and major Capital Works Programs

Position(s)	Target Date	% Complete	Status	Comments
Director Asset Services	30-Jun-2014	25%		Saleyards roofing project being progressed as funding permit.

ACTION: 6.1.1.03. Investigate management options for the Euroa Saleyards

Position(s)	Target Date	% Complete	Status	Comments
Director Asset Services	30-Jun-2014	100%		Special committee charters adopted and committees established.

STRATEGY: 6.1.2. Support history and cultural monuments

ACTION: 6.1.2.01. Continue to support the RSL Avenue of Honour project in main street of Violet Town

Position(s)	Target Date	% Complete	Status	Comments
Director Asset Services	30-Jun-2014	25%		Tree planting project complete and opened. Search underway for missing plaques possibly held by Council.

ACTION: 6.1.2.02. Continue to support Euroa RSL's VC Winners Bronze Statue project

Position(s)	Target Date	% Complete	Status	Comments
Director Asset Services	30-Jun-2014	25%		By agreement, the construction project is being managed by Council's project team.

ACTION: 6.1.2.03. Investigate the development of a long term master plan for the Euroa RSL and Third Age precinct

Position(s)	Target Date	% Complete	Status	Comments
Director Asset Services	30-Jun-2014	%		To be commenced January 2014

STRATEGY: 6.1.3. Deliver Council's bridge replacement in line with industry best practice

ACTION: 6.1.3.01. Review the management plan for Kirwan's Bridge including funding opportunities

Position(s)	Target Date	% Complete	Status	Comments
Director Asset Services	30-Jun-2014	25%		Structural assessment scheduled for March 2014.

ACTION: 6.1.3.02. Support community initiative in securing funding to link the Apex Walking Track across the Seven Creeks near the Rockies

Position(s)	Target Date	% Complete	Status	Comments
Director Sustainable Development	30-Jun-2014	10%		Grant officer is available when community delivers project proposal.

STRATEGY: 6.1.4. Provide passive and active recreational facilities and paths / tracks

ACTION: 6.1.4.01. Investigate the development of a no boating or fishing area at River Street and introduce a no life guard swimming area

Position(s)	Target Date	% Complete	Status	Comments
Manager Statutory Services	30-Jun-2014	100%		The Council Plan nominated no boating area at River Street is currently set aside in the Waterway Rules as prohibited to vessels as per Schedule 91.12(a) and designated by markers accordingly. Whilst Council does not designate swimming areas in the waterway, including the lake, it does set aside no boating areas where passive use of the waterway can be enjoyed.

ACTION: 6.1.4.02. Support the Nagambie Lakes Recreational and Commercial Stakeholders Waterways Committee in implementing the actions in the On-Land and On-Water Strategy

Position(s)	Target Date	% Complete	Status	Comments
Manager Statutory Services	30-Jun-2014	100%		Steven Hicks, Manager Statutory Services provides ongoing support in action implementation as Council representative on the Nagambie Lakes Recreational and Commercial Stakeholders Waterway Committee and Council representative on the Goulburn-Murray Water On-Land On Water Implementation Working Group.

ACTION: 6.1.4.03. Secure funding to develop options for an additional sport and recreation precinct in Nagambie

Position(s)	Target Date	% Complete	Status	Comments
Director Sustainable Development	30-Jun-2014	%		To commence Dec 2013.

ACTION: 6.1.4.04. Repair Violet Town tennis club rooms

Position(s)	Target Date	% Complete	Status	Comments
Manager Projects & Works	30-Jun-2014	5%		Works are planned to start in November 2013

ACTION: 6.1.4.05. Design, develop and apply for funding for a new library in Violet Town

Position(s)	Target Date	% Complete	Status	Comments
Director Asset Services	31-May-2014	25%		Concept plans under development.

ACTION: 6.1.4.06. Continue to support the Euroa Recreational Committee of Management for the redevelopment of Euroa Memorial Oval

Position(s)	Target Date	% Complete	Status	Comments
Chief Executive Officer	31-Jan-2014	40%		Detailed Design completed and an expression of interest submitted to DPCD on the 30th September 2013.

ACTION: 6.1.4.07. Work with shire-wide environment groups to develop programs that deliver community benefits

Position(s)	Target Date	% Complete	Status	Comments
Manager Projects & Works	30-Jun-2014	80%		Council have involved the environmental groups in its projects where required.

STRATEGY: 6.1.5. Provide best practice asset management

ACTION: 6.1.5.01. Advocate for a pedestrian crossing at the railway gates on Birkett Street, Euroa

Position(s)	Target Date	% Complete	Status	Comments
Director Asset Services	30-Jun-2014	25%		Meeting with VicTrack anticipated October 2013

ACTION: 6.1.5.02. Upgrade to digital projection for the Euroa Community Cinema

Position(s)	Target Date	% Complete	Status	Comments
Director Asset Services	30-Jun-2014	%		Tender advertised and closes Friday October 4, 2013.

ACTION: 6.1.5.03. Investigate potential uses for Wesley Hall

Position(s)	Target Date	% Complete	Status	Comments
Director Asset Services	30-Jun-2014	25%		Being considered as part of the Little Theatre relocation project.

ACTION: 6.1.5.04. Clean up town entrances in the Shire

Position(s)	Target Date	% Complete	Status	Comments
Manager Projects & Works	30-Jun-2014	50%		There is an ongoing program of cleaning town entrances within the Shire as required.

ACTION: 6.1.5.05. Investigate and communicate with the community the development of pedestrian crossings in Brock Street, Railway Street and Binney Street area.

Position(s)	Target Date	% Complete	Status	Comments
Director Asset Services	30-Jun-2014	10%		Safety audit completed. Recommendation relating to review of pedestrian crossings to be completed end of December 2013.

ACTION: 6.1.5.06. Provide RV directional signage to Shannon's Lane car park in Euroa

Position(s)	Target Date	% Complete	Status	Comments
Manager Projects & Works	30-Jun-2014	20%		Planning of the project has started but installation is planned to start in January 2014.

ACTION: 6.1.5.07. Continue to design and seek funding for town drainage / sewerage schemes

Position(s)	Target Date	% Complete	Status	Comments
Manager Projects & Works	30-Jun-2014	30%		Council continues to seek funds for projects as the opportunities become available.

ACTION: 6.1.5.08. Investigate the expansion of additional street lights in the Shire

Position(s)	Target Date	% Complete	Status	Comments
Manager Projects & Works	30-Jun-2014	20%		Investigation is underway.

ACTION: 6.1.5.09. Advocate to VicRoads and VicTrack for the creation of a roundabout resulting in a safe intersection at Queen Street / Bank Street / Avenel railway crossing

Position(s)	Target Date	% Complete	Status	Comments
Director Asset Services	30-Jun-2014	50%		Project included in Regional Freight Strategy. Excepted as higher priority for Regional Development Australia funding.

ACTION: 6.1.5.10. Investigate costs for Plain Road, Nagambie, to be sealed as an alternative truck route away from the town centre

Position(s)	Target Date	% Complete	Status	Comments
Manager Projects & Works	30-Jun-2014	20%		Investigation is underway pending funding availability.

ACTION: 6.1.5.11. Widen Nagambie-Locksley Road to a uniform width and improve signage 'to Euroa'

Position(s)	Target Date	% Complete	Status	Comments
Manager Projects & Works	30-Jun-2014	30%		Design is underway. Works on site begins in January 2014

ACTION: 6.1.5.12. Investigate improved signage and road condition of Mullers Road, Nagambie, in line with Council's Road Management Plan

Position(s)	Target Date	% Complete	Status	Comments
Director Asset Services	30-Jun-2014	%		Project to be commenced in October.

ACTION: 6.1.5.13. Seek funding for the Nagambie Main Street Redevelopment Post By-Pass

Position(s)	Target Date	% Complete	Status	Comments
Director Sustainable Development	30-Jun-2014	30%		Approved funding through RDA; however, change in Federal Government has now seen the funding withdrawn. Started to investigate other options.

GOAL: 7 A desirable and safe destination that supports the development of tourism and hospitality enterprises that drive economic growth across our Shire (Tourism and Hospitality)

OBJECTIVE: 7.1. Ensure a coordinated and effective approach to economic and tourism development is maintained at all times

STRATEGY: 7.1.1. Ensure there is consistent branding and marketing of the Shire

ACTION: 7.1.1.01. Advocate to relevant State Government departments for extra tourism funding

Position(s)	Target Date	% Complete	Status	Comments
Director Sustainable Development	30-Jun-2014	30%		Commenced through GRVT Association, who have secured funding for a regional tourism project.

ACTION: 7.1.1.02. Provide RV friendly car parking signage

Position(s)	Target Date	% Complete	Status	Comments
Manager Projects & Works	31-May-2014	10%		Planning of locations for the signs are underway. Installation is earmarked for January 2014

ACTION: 7.1.1.03. Develop a tourist map of all the horse studs in Strathbogie Shire in partnership with North East Thoroughbreds

Position(s)	Target Date	% Complete	Status	Comments
Manager Economic Growth	30-Apr-2014	10%		Still collecting data for the map.

ACTION: 7.1.1.04. Investigate funding for a marketing company to work with tourism groups across the Shire

Position(s)	Target Date	% Complete	Status	Comments
Manager Communications	30-Jun-2014	%		Discussions need to occur with Mel Keogh to look at funding options.

ACTION: 7.1.1.05. Ensure the successful implementation of the Tourism Strategies in the Economic Development Master Plan

Position(s)	Target Date	% Complete	Status	Comments
Manager Economic Growth	30-Jun-2014	%		To be commenced January 2014.

ACTION STATUS CHART

Business Plan - STATUS

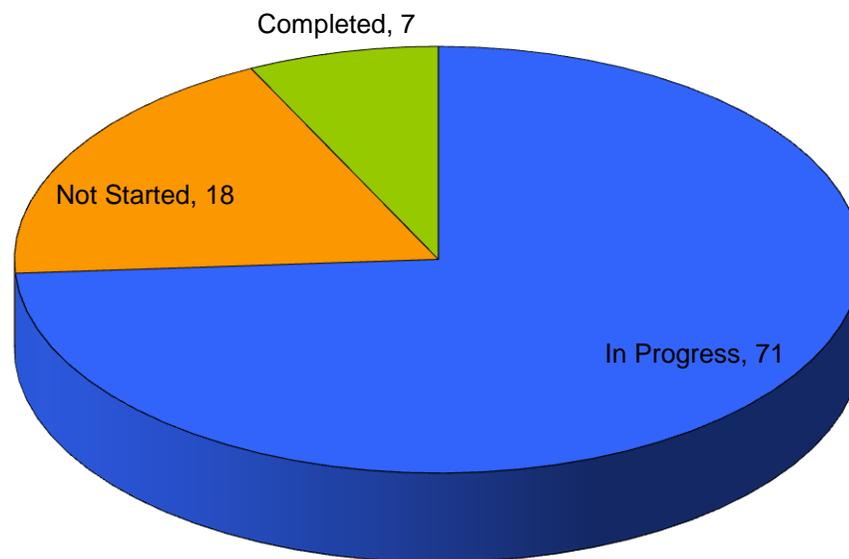

■ In Progress

■ Not Started

■ Completed

ACTION % COMPLETE CHART

Business Plan % COMPLETE

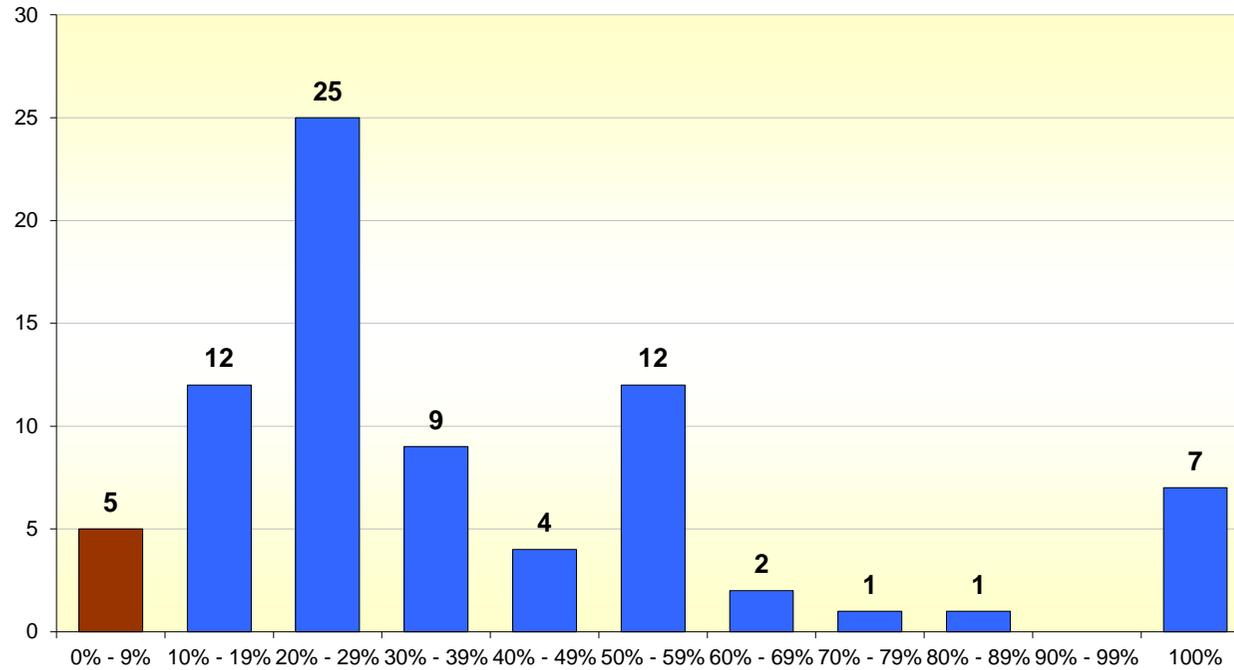

5.7.2 Consideration of Strathbogie Shire Council's Annual Report for the Year ended 30 June 2013

Author & Department

Director, Corporate and Community / Corporate and Community Directorate

Disclosure of Conflicts of Interest in relation to advice provided in this report

The author of this report and officers/contractors providing advice in relation to this report do not have a direct or indirect interest, as provided in accordance with the Local Government Act 1989.

Summary

Council has prepared an Annual Report for the year ended 30 June 2013, in accordance with the requirements of Section 131 of the Local Government Act 1989. A copy of the Report has been submitted to the Minister in accordance with the requirements of the Act. A copy is tabled for information purposes and will be appended to the Minutes of the Meeting for identification purposes.

RECOMMENDATION

That the Annual Report for the year ending 30 June 2013 be adopted.

Background

Council is required under Section 131 of the Local Government Act 1989 to provide the Minister for Local Government with a copy of the Annual Report no later than 3 months following the end of the Financial Year.

The Council must also ensure it receives a copy of the report of the Auditor under Section 9 of the Audit Act 1995 in relation to the Financial Statements, Standard Statements and Performance Statement contained in the abovementioned Annual Report. Section 134 of the Act requires that the report be considered by Council within one month of providing the Annual Report to the Minister.

Alternative Options

The processes undertaken in relation to the Annual Report for the year ending 30 June 2013 are legislated under the Local Government Act 1989. There are no alternative options.

Risk Management

The author of this report considers that there are no significant Risk Management factors relating to the report and recommendation.

Strategic Links – policy implications and relevance to Council Plan

The author of this report considers that the report is consistent with Council Policies, key strategic documents and the Council Plan.

Best Value / National Competition Policy (NCP / Competition and Consumer Act 2010 (CCA) implications

The author of this report considers that the report is consistent with Best Value, National Competition Policy and Competition and Consumer Act requirements.

5.7.2 Consideration of Strathbogie Shire Council's Annual Report for the Year ended 30 June 2013 (cont.)

Financial / Budgetary Implications

The author of this report considers that the recommendation has no capital or recurrent budget considerations.

Economic Implications

The author of this report considers that the recommendation has no significant economic implications for Council or the broader community.

Environmental / Amenity Implications

The author of this report considers that the recommendation has no significant environmental or amenity implications for Council or the broader community.

Community Implications

The author of this report considers that the recommendation has no significant community or social implications for Council or the broader community.

Victorian Charter of Human Rights and Responsibilities Act 2006

The author of this report considers that the recommendation does not limit any human rights under the Victorian Charter of Human Rights and Responsibilities Act 2006.

Legal / Statutory Implications

The author of this report considers that the recommendation has no legal or statutory implications which require the consideration of Council.

Consultation

The author of this report considers that the matter under consideration did not warrant a community consultation process.

Attachments

Nil.

5.7.3 Council Policy **Footpath Trading Policy**

Author & Department

Director, Corporate and Community / Corporate and Community Directorate

Disclosure of Conflicts of Interest in relation to advice provided in this report

Officers providing advice in relation to this report do not have a direct or indirect interest, as provided in accordance with the Local Government Act 1989 (LG Act).

Summary

The Footpath Trading Policy has been reviewed in accordance with the Local Government Act 1979 (The Act). The document was last formally reviewed in March 2009.

RECOMMENDATION

- 1. That Policy CCS 8 Footpath Trading Policy be revoked.**
- 2. That the Footpath Trading Policy, as attached, be adopted.**

Background

Council currently has a Footpath Trading Policy CCS 8. The policy has been reviewed with minor amendments being made. The policy will be reviewed in December 2013 as part of the review of Community Local Law 6. It is expected that the policy will be revoked as part of that process and the provisions of the policy will be included in the amended Local Law.

The policy has been reviewed in accordance with the provisions of the Local Government Act 1989.

Alternative Options

Council has the option to revoke the Policy or amend as it sees fit.

Risk Management

The recommendation addresses issues of footpath trading.

Strategic Links – policy implications and relevance to Council Plan

The report is consistent with Council Policies, key strategic documents and the Council Plan.

Best Value / National Competition Policy (NCP / Competition and Consumer Act 2010 (CCA) implications

The report is consistent with Best Value, National Competition Policy and Competition and Consumer Act requirements.

5.7.3 Council Policy
Footpath Trading Policy (cont.)

Financial / Budgetary Implications

There are no financial budgetary implications associated with this report that have not already been considered.

Economic Implications

The recommendation has no significant economic implications for Council or the broader community.

Environmental / Amenity Implications

The recommendation has no significant environmental or amenity implications for Council or the broader community.

Community Implications

There are no significant community or social implications for Council or the broader community.

Victorian Charter of Human Rights and Responsibilities Act 2006

The recommendation does not limit any human rights under the Victorian Charter of Human Rights and Responsibilities Act 2006.

Legal / Statutory Implications

The recommendation has no further legal or statutory implications which require the consideration of Council.

Consultation

The author of this report considers that the matter under consideration did not warrant a community consultation process.

Attachments

Footpath Trading Policy.



FOOTPATH TRADING POLICY

COUNCIL POLICY	
Effective Date:	21/10/2003
Last Review:	17/03/2009
Current Review:	September 2013
Adopted by Council:
Next Review Date:	Annually
Responsible Officer/s:	Director, Sustainable Development

1. POLICY STATEMENT

The purpose of this policy is to ensure that shop traders, café & restaurant owners provide a safe and accessible trading environment where trading is undertaken on a footpath.

2. POLICY APPLICATION

2.1 Statement of Commitment

Strathbogie Shire Council is committed to ensure traders and the general public enjoy the benefit of footpath trading without exposing the community to physical risk either from pedestrian or vehicular traffic.

2.2 Objectives

Council will develop and monitor Footpath Trading Procedures to work with traders to ensure footpath trading provides a safe environment through:

- Consultation with existing and potential footpath traders
- An effective permit system that considers safety & accessibility
- Implementing risk management practices including process review to minimise risk to the community and continually improve Councils processes

2.3 Authority and Responsibility

2.3.1 Council

- To progressively develop, review and amend as required the Footpath Trading Policy of Council.
- To provide appropriate budgetary support for the development, implementation and enforcement of footpath trading procedures.

2.3.2 Chief Executive Officer

- To promote a culture of teamwork, partnership and responsibility in all sectors and at all levels of the organisation.

2.3.3 Manager Statutory Services

- To monitor the effectiveness of Council's operations
- Liaise with community
- To ensure that the appropriate application forms and risk management processes are carried out by relevant Council staff

2.4 Policy Review Process

This policy is to be reviewed by the end of December each year.

5.7.4 Council Policy Media Policy and Protocols

Author (Position Title) & Department

Director, Corporate and Community / Corporate and Community Directorate

Disclosure of Conflicts of Interest in relation to advice provided in this report

Officers providing advice in relation to this report do not have a direct or indirect interest, as provided in accordance with the Local Government Act 1989 (LG Act).

Summary

The Media Policy has been reviewed in accordance with the Local Government Act 1979 (The Act). The document was last formally reviewed in February 2012.

RECOMMENDATION

- 1. That the Media and Protocols Policy, adopted 21 February 2012, be revoked.**
- 2. That the Media Policy, as attached, be adopted.**

Background

Council currently has a Media Policy and Protocols. The policy has been reviewed with minor amendments being made.

The policy has been reviewed in accordance with the provisions of the Local Government Act 1989.

Alternative Options

Council has the option to revoke the Policy or amend as it sees fit.

Risk Management

The recommendation addresses issues in regard to providing information to the media.

Strategic Links – policy implications and relevance to Council Plan

The report is consistent with Council Policies, key strategic documents and the Council Plan.

Best Value / National Competition Policy (NCP / Competition and Consumer Act 2010 (CCA) implications

The report is consistent with Best Value, National Competition Policy and Competition and Consumer Act requirements.

Financial / Budgetary Implications

There are no financial budgetary implications associated with this report that have not already been considered.

5.7.4 Council Policy
Media Policy and Protocols (cont.)

Economic Implications

The recommendation has no significant economic implications for Council or the broader community.

Environmental / Amenity Implications

The recommendation has no significant environmental or amenity implications for Council or the broader community.

Community Implications

There are no significant community or social implications for Council or the broader community.

Victorian Charter of Human Rights and Responsibilities Act 2006

The recommendation does not limit any human rights under the Victorian Charter of Human Rights and Responsibilities Act 2006.

Legal / Statutory Implications

The recommendation has no further legal or statutory implications which require the consideration of Council.

Consultation

The author of this report considers that the matter under consideration did not warrant a community consultation process.

Attachments

Media Policy and Protocols.



MEDIA POLICY AND PROTOCOLS

COUNCIL POLICY	
Effective Date:	21/02/2012
Last Review:	
Current Review:	September 2013
Adopted by Council:
Next Review Date:	Annually
Responsible Officer/s:	Director, Corporate and Community

1. Purpose

- 1.1 The purpose of this document is to provide clear and concise guidelines relating to the expected processes and procedures that both Councillors and Council staff shall follow in dealing with requests from or making comment to the media.
- 1.2 The document also provides guidelines that will be useful for the media in understanding Council's expectations in relation to the procedures for seeking information from Council or making requests for media comment from Councillors or Council staff. It also provides guidelines for the filming and/or recording of Council meetings.

2. Scope

- 2.1 The policies and protocols in this document apply to both Councillors and Council staff, and reinforce and supplement the guidelines in the Councillor Code of Conduct (18 October 2011) and the Staff Code of Conduct (October 2011).
- 2.2 For the purposes of this document, the term 'media' refers to all forms of media including traditional media such as print, radio and television and also social media forums such as 'twitter', 'youtube' and 'facebook' or any other on-line forum which is accessible to the public such as third party or personal blogs.

3. Principles

- 3.1 In addition to the principles adopted in the Councillor Code of Conduct and the Staff Code of Conduct, all Councillors and staff are committed to providing accurate, transparent and timely information to the media.

4. Media Comment

4.1 Mayor, Deputy Mayor and Councillors

- 4.1.1 The Mayor is the primary spokesperson to the media on behalf of Council where the issue relates to Council policy and/or is of a political, controversial or sensitive nature.
- 4.1.2 Where the Mayor is not available or at his/her discretion, the Mayor may, in the first instance, delegate authority for media comment to the Deputy Mayor or the relevant Ward Councillor/s where the issue is of a specific geographic nature or is of specific interest to a particular Councillor, or as per delegation endorsed at Statutory Meeting.
- 4.1.3 In the event the Mayor may wish to delegate authority to the Deputy Mayor or another Councillor on a particular issue, this shall be undertaken in consultation with the Chief Executive Officer or the Communications Manager to ensure they are adequately briefed.

- 4.1.4 It is desirable, in the first instance, that all requests from the media for comment are directed to the Chief Executive Officer or the Communications Manager who will liaise, in conjunction with the Mayor, to provide the necessary response from the relevant spokesperson.
- 4.1.5 When the Mayor, Deputy Mayor or a Councillor is contacted by the media directly, they should, in the first instance and prior to making comment, contact either the Chief Executive Officer or the Communications Manager to confirm the relevant media spokesperson for the issue and to obtain the necessary information to provide an accurate and timely response.
- 4.1.6 Where the Mayor, Deputy Mayor or Councillor chooses to make comment to the media on issues that may be contrary to Council policy, or on matters not yet formally considered by Council, they should specify the comment is a personal view.

4.2 Chief Executive Officer and Council Staff

- 4.2.1 The Chief Executive Officer is the official media spokesperson for all administrative, operational and management matters pertaining to Strathbogie Shire Council as an organisation including:
- Staffing and structure of the organisation
 - Corporate issues relating to service provision or the day-to-day business or operations of the Council.
- 4.2.2 The Chief Executive Office may delegate authority for media comment to the Communications Manager or another Council Officer at his/her discretion on a case-by-case basis.
- 4.2.3 Under no circumstances should any Council Officer make any comment or express a view to the media about any matters pertaining to the Strathbogie Shire Council without the formal approval of the Chief Executive Officer or the Communications Manager.
- 4.2.4 Where a Council Officer (other than the Communications Manager) is delegated authority by either the Chief Executive Officer or the Communications Manager to make media comment, it shall generally be limited to commentary on matters of a technical nature.
- 4.2.5 All requests from the media for comment on administrative, operational and management matters should be directed to the Chief Executive Officer or the Communications Manager who will liaise to provide the necessary response from the relevant spokesperson.
- 4.2.6 All media inquiries or requests for comment on all local emergencies and natural disasters (such as fire and flood) should be directed to the Chief Executive Officer or the Communications Manager.

5. Filming and/or Recording of Council Meetings

- 5.1 In the first instance, any media outlet and/or community representative must submit a request in writing to the Communications Manager if they wish to film or record any proceedings of a Council or Council-run meeting.
- 5.2 The Communications Manager shall forward the request to the Mayor, Deputy Mayor, all Councillors and the Chief Executive Officer for noting.
- 5.3 Unless otherwise advised by the Chief Executive Officer (in consultation with the Mayor), permission **may** be granted.
- 5.4 Permission **may** only granted for filming on the basis the camera/camera crew adopts a fixed position and is not moving around the meeting room. Any exception to this provision must be approved in writing by the Chief Executive Officer or Communications Manager.
- 5.5 Journalists may use laptop computers to make notes for Council meetings.

Reference Documents:

Reference 1 – Strathbogie Shire Council Staff Code of Conduct

Reference 2 – Strathbogie Shire Council Councillor Code of Conduct

Reference 3 – Strathbogie Shire Council Social Media Policy

5.7.5 **Council Policy** **Risk Management Policy**

Author & Department

Director, Corporate and Community / Corporate and Community Directorate

Disclosure of Conflicts of Interest in relation to advice provided in this report

Officers providing advice in relation to this report do not have a direct or indirect interest, as provided in accordance with the Local Government Act 1989 (LG Act).

Summary

The Risk Management Policy has been reviewed in accordance with the Local Government Act 1979 (The Act). The document was last formally reviewed in October 2011.

RECOMMENDATION

1. **That Policy CCS 1 'Risk Management Policy' be revoked.**
2. **That the attached Risk Management Policy be adopted.**

Background

The Risk Management Policy states Councils commitment to the principles of Risk Management and to outline its objectives and organisational responsibilities for the implementation and management of effective Risk Management procedures.

The Risk Management Strategy is an active document that is used by Council staff and has been reviewed by Council.

The policy has been reviewed in accordance with the provisions of the Local Government Act 1989.

Alternative Options

Council has the option to revoke the Policy or amend as it sees fit.

Risk Management

The recommendation does not contain any significant risk factors.

Strategic Links – policy implications and relevance to Council Plan

The report is consistent with Council Policies, key strategic documents and the Council Plan.

Best Value / National Competition Policy (NCP / Competition and Consumer Act 2010 (CCA) implications

The report is consistent with Best Value, National Competition Policy and Competition and Consumer Act requirements.

5.7.5 **Council Policy** **Risk Management Policy (cont.)**

Financial / Budgetary Implications

There are no financial budgetary implications associated with this report that have not already been considered.

Economic Implications

The recommendation has no significant economic implications for Council or the broader community.

Environmental / Amenity Implications

The recommendation has no significant environmental or amenity implications for Council or the broader community.

Community Implications

There are no significant community or social implications for Council or the broader community.

Victorian Charter of Human Rights and Responsibilities Act 2006

The recommendation does not limit any human rights under the Victorian Charter of Human Rights and Responsibilities Act 2006.

Legal / Statutory Implications

The recommendation has no further legal or statutory implications which require the consideration of Council.

Consultation

The author of this report considers that the matter under consideration did not warrant a community consultation process.

Attachments

Risk Management Policy



RISK MANAGEMENT POLICY

COUNCIL POLICY	
Effective Date:	15/07/1997
Last Review:	18/10/2011
Current Review:	September 2013
Adopted by Council:
Next Review Date:	Annually
Responsible Officer/s:	Director, Corporate and Community

1. POLICY STATEMENT

The purpose of this policy is to state Council's commitment to the principles of Risk Management and to outline its objectives and organisational responsibilities for the implementation and management of effective Risk Management procedures.

2. POLICY APPLICATION

2.1 Definition

Risk is uncertain future events that could influence the achievement of Council's strategic and operational objectives.

2.2 Statement of Commitment

Strathbogie Shire Council is committed to the goal of identifying, preventing, managing and controlling foreseeable risks which might occur within its areas of operations.

The risks include but are not limited to:

- Personnel (occupational health and safety)
- Public Liability/Professional Indemnity
- Plant and property
- Financial
- Business interruption
- Natural Disasters

Council acknowledges that the involvement of its management, employees, contractors and community is critical to the success of its risk management program and will support and encourage input from all sectors of the organisation and from the general community.

2.3 Objectives

Through its commitment to Risk Management principles and associated procedures, Council seeks to:

- Reduce all identified risk to the lowest practicable level to satisfy Council's risk appetite, ie mitigating risk to an acceptable level.
- Identify and analyse, evaluate, control and document Council's risk exposure.
- Identify and implement controls to reduce risk and eliminate high risk activities.
- Monitor and review risks to ensure risk exposure remains within acceptable levels.
- Create a workplace culture where all staff assume responsibility for managing risk in their day to day works.
- Raise the awareness of risk management and educate employees on good risk management practices.
- Ensure accountability/responsibility is assumed for risk management at all levels.

- Implement a Risk Management Strategy to achieve better risk management organisationally and to review the strategy annually.
- Effectively manage risks in the Public Liability, Professional Indemnity and Occupational Health & Safety areas.
- Ensure compliance with relevant legislation, regulations and industry standards.
- Maximise opportunities for the development of the organisation and the community.
- Reduce the costs to Council of insuring against risk.

2.4 Strategies

Council seeks to achieve its objectives through the following strategies:

- Establish and maintain a Risk Management Committee to oversee management of organisational strategic risk.
- Continue to promote a consistent language for risk and risk management across the organisation.
- Develop an awareness needs analysis and a communication strategy to promote an improved awareness and understanding of risk.
- Implement,
- Develop simple risk management aide documentation to meet specialist business needs, e.g.: project risk, tender process risk, safety risk, planning risk.
- Establish an information page on the Strathbogie Shire Council's intranet site.
- Continue to develop staff to establish 'risk specialists' within the organisation.
- Develop a program of information articles on risk management for in house communications
- Continue the deployment of the Risk Management Framework through training programs, risk workshops and at team meetings.
- Promote increased awareness of fraud risk management issues through team meetings.
- Maintain a staffing position of Corporate Risk Officer dedicated to implementation of this policy.
- Develop a Risk Register (InterPlan Risk module) which accords with Australian/New Zealand Standard (AS/NZS ISO 13000:2009), separating strategic risk from operational risk and ensuring the safety and integrity of dataProvide suitable education and training for all employees on loss prevention and risk identification.
- Encourage early reporting of incidents and risks to prevent further losses.
- Conduct regular risk audits of all areas of Council operations.
- Develop and implement effective hazard reporting and response procedures.
- Ensure the integrity of publicly circulated information.
- Develop and introduce appropriate risk management performance measurement criteria.

2.5 Authority and Responsibility

2.5.1 Council

- To progressively develop, review and amend as required the risk management policy of Council
- To provide appropriate budgetary support for the development, implementation and maintenance of a risk management register and associated identification, analysis and treatment procedures in accordance with AS/NZS ISO 13000:2009.
- To provide for the consideration of risk register data in the preparation of the Council Plan and Budget.
- To provide appropriate budgetary support for the position of Corporate Risk Officer.

2.5.2 Risk Management Committee

- Overseeing the development and maintenance of the Risk Management Strategy.
- Identifying Council's strategic risk exposure.
- Overseeing the preparation of an annual Strategic Risk Assessment.
- Overseeing the preparation and maintenance of the Risk Register.
- Considering any matters relating to the identification, assessment, monitoring and management of strategic risks associated with the operation of Strathbogie Shire Council.
- Ensuring that all strategic risks are adequately mitigated.
- Reviewing the adequacy and effectiveness of the risk management system.
- Ensuring that effective risk management policies, systems and structures are in place to identify and manage all strategic risks.
- Ensuring that appropriate systems and processes are in place for emergency response, crisis management and business continuity.
- Recommending reinsurance arrangements.
- Assessing and monitoring the effectiveness of strategic risk mitigation.
- Identifying and addressing any material change to the strategic risk profile of Strathbogie Shire Council.
- Reviewing the terms of reference at least annually.

2.5.3 Chief Executive Officer

- To promote a culture of risk management awareness and responsibility in all sectors and at all levels of the organisation.
- Ensure risk is appropriately managed and policy maintained and delivered.
- Oversee embedding of risk management into key areas and approval processes of all major process and functions.

2.5.4 Directors

- To promote the Identification, evaluation and documentation of risks in accordance with policy and ensure existing and new risks are effectively managed.
- Maintain sound risk management practices.
- Create an environment where risk management is accepted as responsibility of staff.
- To ensure the development and promotion of risk identification procedures.

2.5.5 Supervisors

- Maintaining sound risk management practices.
- Conducting risk assessments.
- Implementing allocated risk controls and reporting progress.

2.5.6 Corporate Risk Officer

- Measure risk management performance and reporting to the Senior Management Team, Executive Management Team and the Audit Committee.
- Implementation of policy and associated procedures.
- Ongoing review and maintenance of policy and procedures.
- Developing, implementing and maintaining the framework for managing risk.
- Provision of risk management advice and facilitation of risk management awareness throughout the organisation.
- Coordinating the establishment and maintenance of Council's risk register.
- Providing staff training programs relevant to the policy.

2.5.7 Managers

- To promote and support the provision of a safe and healthy work environment and regularly report to staff and senior management.
- To liaise with staff to manage risk associated with their department
- To liaise with staff and coordinate development of risk management procedures
- To liaise and investigate risk management related claims

2.5.8 Employees, Volunteers and Contractors

- Actively participate in the identification and analysis of risks and contribute to implementation of identified controls.
- Perform their duties in accordance with risk management provisions of their position description or contract.

3. Relevant Legislation

- Occupational Health & Safety Act 2004. Governs requirements for risk management associated with health and safety in the workplace.

4. Documentation

- Risk Management Strategy
- Health & Safety Policy
- Fraud Management Policy
- Design Risk Assessment Procedure
- Business Continuity Plan
- Pandemic Plan

5.7.6 Council Policy
Muted Tones Policy

Author & Department

Director, Corporate and Community / Corporate and Community Directorate

Disclosure of Conflicts of Interest in relation to advice provided in this report

Officers providing advice in relation to this report do not have a direct or indirect interest, as provided in accordance with the Local Government Act 1989 (LG Act).

Summary

The Muted Tones Policy has been reviewed in accordance with the Local Government Act 1979 (The Act). The document was last formally reviewed in May 2006.

RECOMMENDATION

That Policy C&E 18 'Muted Tones Policy' be revoked.

Background

Council currently has a Muted Tones Policy C&E 18. The policy has been reviewed and recommended to be revoked. The reason for the recommendation is that the building code and the planning scheme already provide for all of the requirements laid out in the policy. In addition, both the building code and the planning scheme are updated regularly to reflect contemporary practices.

The policy has been reviewed in accordance with the provisions of the Local Government Act 1989.

Alternative Options

Council has the option to revoke the Policy or amend as it sees fit.

Risk Management

The recommendation addresses the fact that the building code and planning scheme provide for all of the provisions of the existing policy.

Strategic Links – policy implications and relevance to Council Plan

The report is consistent with Council Policies, key strategic documents and the Council Plan.

Best Value / National Competition Policy (NCP / Competition and Consumer Act 2010 (CCA) implications

The report is consistent with Best Value, National Competition Policy and Competition and Consumer Act requirements.

5.7.6 Council Policy
Muted Tones Policy (cont.)

Financial / Budgetary Implications

There are no financial budgetary implications associated with this report that have not already been considered.

Economic Implications

The recommendation has no significant economic implications for Council or the broader community.

Environmental / Amenity Implications

The recommendation has no significant environmental or amenity implications for Council or the broader community.

Community Implications

There are no significant community or social implications for Council or the broader community.

Victorian Charter of Human Rights and Responsibilities Act 2006

The recommendation does not limit any human rights under the Victorian Charter of Human Rights and Responsibilities Act 2006.

Legal / Statutory Implications

The recommendation has no further legal or statutory implications which require the consideration of Council.

Consultation

The author of this report considers that the matter under consideration did not warrant a community consultation process.

Attachments

Nil.

5.7.7 Council Policy ICT Vendor Access Policy

Author & Department

Director, Corporate and Community / Corporate and Community Directorate

Disclosure of Conflicts of Interest in relation to advice provided in this report

Officers providing advice in relation to this report do not have a direct or indirect interest, as provided in accordance with the Local Government Act 1989 (LG Act).

Summary

The ICT Vendor Access Policy has been reviewed in accordance with the Local Government Act 1979 (The Act). The document was last formally reviewed in May 2011.

RECOMMENDATION

That Policy ICT 3 'ICT Vendor Access Policy' be revoked.

Background

The policy relates to allowing IT vendors access to Council systems to assist in the installation and maintenance of software applications. This is considered to be a working process that is undertaken on a needs basis, dependent upon any maintenance or upgrade works that are required. Accordingly, the IT Co-Ordinator determines access rights to ensure he can manage the network in the best interests of the business. The recommendation is to revoke the policy and have it remain as a Chief Executive Officer directive.

The policy has been reviewed in accordance with the provisions of the Local Government Act 1989.

Alternative Options

Council has the option to revoke the Policy or amend as it sees fit.

Risk Management

The recommendation does not contain any significant risk factors.

Strategic Links – policy implications and relevance to Council Plan

The report is consistent with Council Policies, key strategic documents and the Council Plan.

Best Value / National Competition Policy (NCP / Competition and Consumer Act 2010 (CCA) implications

The report is consistent with Best Value, National Competition Policy and Competition and Consumer Act requirements.

Financial / Budgetary Implications

There are no financial budgetary implications associated with this report that have not already been considered.

5.7.7 Council Policy
ICT Vendor Access Policy

Economic Implications

The recommendation has no significant economic implications for Council or the broader community.

Environmental / Amenity Implications

The recommendation has no significant environmental or amenity implications for Council or the broader community.

Community Implications

There are no significant community or social implications for Council or the broader community.

Victorian Charter of Human Rights and Responsibilities Act 2006

The recommendation does not limit any human rights under the Victorian Charter of Human Rights and Responsibilities Act 2006.

Legal / Statutory Implications

The recommendation has no further legal or statutory implications which require the consideration of Council.

Consultation

The author of this report considers that the matter under consideration did not warrant a community consultation process.

Attachments

Nil.

5.7.8 Council Policies **- Review of Asset Services Policies**

Author & Department

Director, Asset Services

Disclosure of Conflicts of Interest in relation to advice provided in this report

Officers providing advice in relation to this report do not have a direct or indirect interest, as provided in accordance with the Local Government Act 1989 (LG Act).

Summary

The Asset Services Policies have been reviewed in accordance with the Local Government Act 1979 (The Act).

The majority of the asset services policies have been reviewed with only minor amendments being made. The amendments have been framed to align the policies with current practice and to reflect the 2013-2017 Strathbogie Shire Council Plan.

Five policies are recommended to be revoked because they have been superseded by other documentation or programs. These are:

1. A.S. 19, Staff Attending Emergencies – superseded by EBA provisions
2. A.S. 13, Unsealed Roads Maintenance – superseded by Road Management Plan
3. A.S. 14, Gravel Roads Maintenance – superseded by Road Management Plan
4. A.S. 16, Local Roads and Bridges – superseded by Asset Management Plan.
5. D.S. 2, Pest Plant and Animal Management on Council Controlled Land – superseded by Roadside Weed and Pest Management Program. Priorities are now established in consultation with Landcare Groups.

5.7.8 Council Policies
- Review of Asset Services Policies (cont.)

RECOMMENDATION	
That Policies -	
<ol style="list-style-type: none"> 1. A.S. 9 Contract Management and Control 2. A.S. 10 Footpath Construction and Reconstruction 3. A.S. 11 Rural Road Reserve Revegetation 4. A.S. 12 Urban Tree 5. A.S. 13 Unsealed Roads Maintenance 6. A.S. 14 Gravel Roads Maintenance 7. A.S. 15 Roadside Maintenance-Spraying and Slashing 8. A.S. 16 Local Roads and Bridges 9. A.S. 17 Roadside Fatalities Memorials 10. A.S. 18 Total Asset Management 11. A.S. 19 Staff Attending Emergencies 12. A.S. 20 Vehicle Crossing to Access Private Land from a Public Road 13. A.S. 21 Public Road Register 14. A.S. 22 Playgrounds Management 15. A.S. 23 Road Naming 16. A.S. 24 Special Rate and Charge Scheme (Infrastructure) 17. A.S. 25 Firearms 18. C.C.S. Council Reserves and Facilities 19. C.&E. Tourism Related Directional Signage 20. D.S. 2 Pest Plant and Animal Management on Council Controlled Land 	<ol style="list-style-type: none"> 1. Contract Management and Control 2. Footpath Construction and Reconstruction 3. Rural Road Reserve Revegetation 4. Urban Tree 5. Roadside Maintenance-Spraying and Slashing 6. Roadside Fatalities Memorials 7. Total Asset Management 8. Vehicle Crossing to Access Private Land from a Public Road 9. Public Road Register 10, Playgrounds Management 11. Road Naming 12. Special Rate and Charge Scheme (Infrastructure) 13. Firearmrs 14. Council Reserves and Facilities 15. Tourism Related Directional Signage
<p>be revoked, as listed above.</p>	<p>be adopted, as listed above.</p>

Background

A number of the asset services policies date back to the mid 1990's. Most of the policies have been updated and are recommended for adoption as amended. Others have been superseded and revocation is recommended.

9.7.7 Council Policies Update
- Asset Services (cont.)

Alternative Options

Council has the option to revoke the Policies or amend as it sees fit.

Risk Management

The author considers that there are no significant Risk Management factors relating to the report and recommendation.

Strategic Links – policy implications and relevance to Council Plan

The report is consistent with Council Policies, key strategic documents and the Council Plan.

Best Value / National Competition Policy (NCP / Competition and Consumer Act 2010 (CCA) implications

The report is consistent with Best Value, National Competition Policy and Competition and Consumer Act requirements.

Financial / Budgetary Implications

There are no financial budgetary implications associated with this report that have not already been considered.

Economic Implications

The recommendation has no significant economic implications for Council or the broader community.

Environmental / Amenity Implications

The recommendation has no significant environmental or amenity implications for Council or the broader community.

Community Implications

There is no significant community or social implications for Council or the broader community.

Victorian Charter of Human Rights and Responsibilities Act 2006

The recommendation does not limit any human rights under the Victorian Charter of Human Rights and Responsibilities Act 2006.

Legal / Statutory Implications

The recommendation has no further legal or statutory implications which require the consideration of Council.

Consultation

The author of this report considers that the matter under consideration did not warrant a community consultation process.

Attachments

Asset Services Policies



CONTRACT MANAGEMENT AND CONTROL POLICY

COUNCIL POLICY	
Effective Date:	17/02/1999
Last Review:	18/02/2003
Current Review:	October 2013
Adopted by Council:	
Next Review Date:	
Responsible Officer	Director Asset Services

POLICY STATEMENT

The purpose of this Policy is to define Council's objective with respect to the management and administration of Council Contracts with external and in-house providers.

POLICY APPLICATION

Type of Contract

Prior to the development of any Specification the type and full details of the Contract required are determined, ie: lump sum, schedule of rates, quality assurance.

Contract Scope

Construction Contracts

All Council construction contracts shall be Quality Assurance Contracts.

Quality Assurance Contracts require systems in place that provide assurance of works performed to specification. Much of this assurance is in the production of documentation by the Contractor.

Design and Construct Contracts

Design and construct Contracts are to be used, under a given set of circumstances, such as a major bridge construction on a designated route. Design and construct contracts also incorporate the provision of Quality Assurance.

VicRoads Funded Projects

All VicRoads funded Contracts use specifications developed and provided by VicRoads.

Under VicRoads funding guidelines, any Contract for works to be funded by VicRoads must be awarded to the lowest conforming tenderer at all times.

Goods and Services Contracts

All Contracts for goods and services are either Lump Sum or Schedule of Rates Contracts.

General Conditions of Contract

General Conditions of Contract that may be used in Council Contracts include:-

- General Conditions of Contract – Services (Prepared by Council)
- General Conditions of Contract – Goods (Prepared by Council)
- AS 2124-1992 General Conditions of Contract
- AS 4305-1996 Minor Works Contract Conditions
- AS4000-1997 General Conditions of Contract (New)
- VicRoads General Conditions of Contract (NPWC3).

All General Conditions of Contract include an Annexure which is contract specific and forms an integral part of a Contract.

Tender Process

All tendering conducted by Strathbogie Shire Council shall be in accordance with the Strathbogie Shire Council Code of Tendering. Procedures and processes shall also comply with the Local Government Act 1989 and any other relevant State and Federal legislation.

Particular attention shall be given to ensuring that the Tender process is auditable, encourages competitive bidding, protects commercial confidentiality and that there is no conflict of interest.

All Councillors and Council staff must ensure probity of the Tender process at all times, including compliance with the following Council Policies:-

- Privacy Policy
- Governance and Protocols Code
- Competition Code and Trade Practices Act Compliance Policy.

Only the nominated Contract representative stated in the tender or contract documentation or Council's Contracts Officer may handle enquiries from tenderers.

Canvassing of Councillors or Council officer is not permitted and the submitter of any tender who seeks to canvass a Councillor or Council officer individually will not be considered.

Conforming and Non Conforming Tenders

Non conforming tenders are tenders that do not conform to what is required by the Specification. In some circumstances, after you add the value of the non conformance, the non conforming tender may be accepted providing the same outcome is apparent

Administration and Management

Financial Control

A clear concise payment form will be used for all payments of Contracts.

Partnering

Council may adopt a partnering relationship with the Contractor. Whilst still taking into account the specification and contract documentation requirements, where necessary an attempt shall be made to be flexible under certain conditions. This flexible approach between both Council and the Contractor should result in a better outcome for the project.

Surveillance

All Contracts shall be subject to surveillance throughout their term.

Audit

All Contracts may be audited throughout their term.

The Superintendent shall undertake the audit and may utilise the assistance of external agencies from time to time.

Non Compliance Items

For quality assurance contracts, items under a contract that are found to be non conforming to the specification by the Superintendent and have not been identified by the Contractor, will be brought to the attention of the Contractor by a Non Compliance Report. This action follows failure of the Contractor to act on verbal advice of the non compliance.

Non Conformance

For quality assurance contracts, the Contractor may raise a Non Conformance Report based on observations of specification variance or following verbal or written advice (Non Compliance Report) from the Superintendent or Superintendent's Representative.

Site Meetings

Regular site meetings will be held with all Contractors that hold long term contracts, ie: more than one month. All non conformances, contract variations and other items will dealt with at that site meeting.

Contract Review

Each renewable Contract shall be reviewed prior to readvertising of that Contract.

Long term contracts shall be reviewed at a frequency agreed in the Contract or when items of conflict are raised by the Contractor or Principal.

Monitoring

All Contracts shall be reviewed on predetermined dates, or when certain degrees of progress have been achieved. The reviews will be conducted by Council's Contracts Department or the nominated Contract Superintendent. The review timetable will be determined prior to the commencement of each Contract.



FOOTPATH CONSTRUCTION & RECONSTRUCTION POLICY

COUNCIL POLICY	
Effective Date:	21/09/1999
Last Review:	18/02/2001
Current Review:	October 2013
Adopted by Council:	
Next Review Date:	
Responsible Officer	Director Asset Services

POLICY STATEMENT

The purpose of this policy is to define Council's objective of providing a safe network of footpaths for movement of pedestrians within all urban areas of the Strathbogie Shire.

POLICY APPLICATION

This policy applies to the provision of new footpaths required in subdivision, private driveway construction, construction by Council of new footpaths (under a special benefit scheme) and reconstruction of replacement footpaths. The definition of pedestrians also includes motorised wheelchairs and other users defined under the Road Safety (Traffic) Regulations.

Location of Future Footpaths

Council has developed plans showing Designated Footpath Areas.

The location for placement of footpaths is based on a demonstrated need, and/or formalisation of natural links.

Renewal priority has been determined using existing footpath locality and a need to provide links between major pedestrian traffic generators including schools, shops and other community facilities and residential areas. Consideration will also given to the age and nature of pedestrians using the proposed path, the classification of the abutting road, and possible conflict between vehicle and pedestrian traffic.

Motorised wheelchair routes are also included in future footpath plans.

Consultation with relevant stakeholders will be undertaken when considered appropriate.

Council will consider all proposals for capital expenditure in accordance with the Council's Asset Management Policy.

Footpath Construction Materials

Council's preferred footpath construction material is concrete. Other construction materials will be considered, and approved for use if deemed appropriate, and the material and the effect blend with the surrounding developments.

Council will take into consideration the life cycle costs of alternative materials.

Council's liability to contribute to the renewal or construction, of a footpath will be limited to a maximum of its contribution for the construction of a standard concrete footpath.

Construction Standard

Council's footpath construction standards are:

Width:	1500mm
Depth:	75mm reinforced (pedestrian only areas)
	130mm reinforced (light vehicular traffic areas)
	160mm reinforced (heavy vehicular traffic)
Crossfall	2% generally
	Set from fenced (property) line. Generally .35m dependent on site conditions. Can be offset up to a maximum of 0.5m.

ResCode suggests a footpath on one side of road only in particular areas. Council has prepared a draft proposal Designated Footpath Areas (DFA's). Refer to Footpath Plan (E-Stra 21.1.98 FP 9801/1). Where appropriate existing 1.2m wide footpaths will be replaced to a width of 1.5m when existing paths require renewal.

Contribution for New Footpath Construction (other that subdivisions)

For Standard 1.5m wide footpaths: abutting owners to contribute 50% of cost completed under a Special Benefit Scheme.

Any width greater than 1.5m (at request of abutting land owners): abutting owners to contribute 100% of the greater width. This also applies to infill behind the back of the footpath to the fence line.

Private Driveways

Private Driveways are the full responsibility of the owner.

Subdivision

Footpaths within, and abutting, subdivisions are to be constructed at full cost to the subdivision developer.

Footpath Inspection and Maintenance

Footpath inspection and maintenance will be performed in accordance with Council's Maintenance Plan.



RURAL ROAD RESERVE REVEGETATION POLICY

COUNCIL POLICY	
Effective Date:	21/09/1999
Last Review:	20/02/01
Current Review:	October 2013
Adopted by Council:	
Next Review Date:	
Responsible Officer	Director Asset Services

POLICY STATEMENT

The purpose of this policy is to ensure that vegetation planted on rural road reserves is performed in a manner that ensures Councils' assets in road formation and drainage are preserved. Also, to ensure that the aesthetics, amenity and heritage of the locality is maintained.

POLICY APPLICATION

This policy applies to all works performed on rural road reserves including works by local landowners, Catchment Management Authority Implementation Groups, Landcare Groups, Community Groups, and Council programs.

Road User Safety

New roadside revegetation must be performed in a manner that ensures safety standards are met. Where applicable, roadside clear zones and sight distances on curves and intersections will be maintained in accordance with VicRoads Guidelines – Part 3, Section 3.9.

Planting Plans

Individuals or groups wishing to plant on roadsides must gain Council permission before proceeding with planting. Planting Plans shall be forwarded to Council's Director Asset Services.

Plans should consider the following:

- Existing vegetation
- The Ecological Vegetation Classification (EVC's) of the area.
- Disturbance of existing conditions
- Location of services
- Traffic sight distance
- Offset clearances – *including "clear zone" requirements in accordance with attached guidelines*
- Follow up maintenance – short and long term
- Weed control
- Adequate property access and pedestrian movement
- Fire prevention requirements
- Correct indigenous species
- Traffic Management Plan

Guidelines for the implementation of revegetation are contained in Council's Roadside Management Plan. Sight Distances are defined in VicRoads Technical Bulletin No. 36.

Landowner Consultation

Adjoining landowner consultation is an integral part of the process where revegetation is to occur. Every effort will be made to ensure the needs of the landowner are addressed.

Types of Vegetation

Generally, only vegetation indigenous to the locality is to be planted, however consideration will be given to other requests.

The proponents shall determine the ecological vegetation classification for the planting area, and ensure that the proposed plantings comply with the requirements of the vegetation management framework.

Fencing Within Road Reserves

Fencing within road reserves to protect plantations from driven stock is not permissible.

Landcare and Conservation Issues - Revegetation and Natural Regeneration

Natural regeneration is the regeneration of indigenous species by setting seed or suckering. Restoration and revegetation is often needed to supplement natural regeneration in areas where roadsides have been substantially modified.

Permits

- Approval is required – contact Shire Planning Officer.

Principles

- Maximise revegetation and regeneration with local indigenous species, except where there are safety considerations.
- protect high conservation value roads.

Implementation

1. Only natural regeneration on areas of high conservation value.
2. Native grasslands and native grassy woodland should not be removed to plant trees.
3. Prior to approval being given for restoration or revegetation programs on roadsides, plans must be submitted to Council ensuring that :
 - it will not interfere with current or future service provision.
 - all services can be clearly marked, identified and avoided with plantings.
 - the type of weed control is appropriate to the site.
 - the correct indigenous vegetation is being used.
 - the group initiating the revegetation program are able to maintain the plants *and control weeds* for at least 2 years.
 - the long term maintenance of the site has been considered.
 - plantings are to maintain a minimum clearance of:-
 - 1.0m from back of drain
 - 1.0m from fence
 - 180m from any intersection
 - 60m from any private entrance
 - 250m sight distance
 - plantation spacing of 20m every 100m for fire prevention access.
 - minimum disturbance occurs to the existing flora and soil conditions.



RURAL ROAD RESERVE REVEGETATION POLICY

COUNCIL POLICY	
Effective Date:	21/09/1999
Last Review:	20/02/01
Current Review:	October 2013
Adopted by Council:	
Next Review Date:	
Responsible Officer	Director Asset Services

POLICY STATEMENT

The purpose of this policy is to ensure that vegetation planted on rural road reserves is performed in a manner that ensures Councils' assets in road formation and drainage are preserved. Also, to ensure that the aesthetics, amenity and heritage of the locality is maintained.

POLICY APPLICATION

This policy applies to all works performed on rural road reserves including works by local landowners, Catchment Management Authority Implementation Groups, Landcare Groups, Community Groups, and Council programs.

Road User Safety

New roadside revegetation must be performed in a manner that ensures safety standards are met. Where applicable, roadside clear zones and sight distances on curves and intersections will be maintained in accordance with VicRoads Guidelines – Part 3, Section 3.9.

Planting Plans

Individuals or groups wishing to plant on roadsides must gain Council permission before proceeding with planting. Planting Plans shall be forwarded to Council's Director Asset Services.

Plans should consider the following:

- Existing vegetation
- The Ecological Vegetation Classification (EVC's) of the area.
- Disturbance of existing conditions
- Location of services
- Traffic sight distance
- Offset clearances – *including "clear zone" requirements in accordance with attached guidelines*
- Follow up maintenance – short and long term
- Weed control
- Adequate property access and pedestrian movement
- Fire prevention requirements
- Correct indigenous species
- Traffic Management Plan

Guidelines for the implementation of revegetation are contained in Council's Roadside Management Plan. Sight Distances are defined in VicRoads Technical Bulletin No. 36.

Landowner Consultation

Adjoining landowner consultation is an integral part of the process where revegetation is to occur. Every effort will be made to ensure the needs of the landowner are addressed.

Types of Vegetation

Generally, only vegetation indigenous to the locality is to be planted, however consideration will be given to other requests.

The proponents shall determine the ecological vegetation classification for the planting area, and ensure that the proposed plantings comply with the requirements of the vegetation management framework.

Fencing Within Road Reserves

Fencing within road reserves to protect plantations from driven stock is not permissible.

Landcare and Conservation Issues - Revegetation and Natural Regeneration

Natural regeneration is the regeneration of indigenous species by setting seed or suckering. Restoration and revegetation is often needed to supplement natural regeneration in areas where roadsides have been substantially modified.

Permits

- Approval is required – contact Shire Planning Officer.

Principles

- Maximise revegetation and regeneration with local indigenous species, except where there are safety considerations.
- protect high conservation value roads.

Implementation

1. Only natural regeneration on areas of high conservation value.
 2. Native grasslands and native grassy woodland should not be removed to plant trees.
 3. Prior to approval being given for restoration or revegetation programs on roadsides, plans must be submitted to Council ensuring that :
 - it will not interfere with current or future service provision.
 - all services can be clearly marked, identified and avoided with plantings.
 - the type of weed control is appropriate to the site.
 - the correct indigenous vegetation is being used.
 - the group initiating the revegetation program are able to maintain the plants *and control weeds* for at least 2 years.
 - the long term maintenance of the site has been considered.
 - plantings are to maintain a minimum clearance of:-
 - 1.0m from back of drain
 - 1.0m from fence
 - 180m from any intersection
 - 60m from any private entrance
 - 250m sight distance
- } * must be past "clear zone"
} width also
- plantation spacing of 20m every 100m for fire prevention access.
 - minimum disturbance occurs to the existing flora and soil conditions.



URBAN TREE POLICY

COUNCIL POLICY	
Effective Date:	21/09/99
Last Review:	18/02/03
Current Review:	October 2013
Adopted by Council:	
Next Review Date:	
Responsible Officer	Director, Asset Services

POLICY STATEMENT

The purpose of this policy is to set guidelines for the management of Council's urban tree assets throughout municipality including new plantings, removal and replacement.

The management of the urban tree assets will be performed in a structured and co-ordinated way.

The policy is based on the need to achieve a balance between the management of risk the Council is exposed to through the presence of trees in the urban environment, the need to preserve, develop and improve the amenity of our urban areas, and enhance their natural environmental values and benefits.

POLICY APPLICATION

This policy will apply to all urban areas within the Shire of Strathbogie.

POLICY APPLICATIONS

The following are the key principles that define the Strathbogie Shire Council's Urban Tree Policy:

All tree removal, maintenance, management and/or planting must have council's approval prior to the works being undertaken

New trees will be planted in the Shire of Strathbogie to maintain and enhance the canopy cover in a planned and programmed manner.

Trees provide both environmental and aesthetic benefits to the community. Council will consider opportunities to increase the number of trees within the urban areas. Tree Planting Programs, including Precinct and Park plans will be developed to provide the direction to future planting programs.

Excellent tree management practices will be maintained at all times.

These management practices include:

- Planning processes, including risk management considerations
- Compliance with relevant legislation
- Development of tree management systems
- Inspection regimes
- Tree maintenance standards

A diverse range of native and exotic tree species appropriate to the Shire's urban areas will be maintained.

Planting programs will be developed with community and stakeholder consultation. Planting programs will consider a number of factors including, as appropriate; preservation of the historic character of particular areas, strengthening of existing themes and the introduction of more contemporary landscaping.

Tree species will be selected for planting after consideration of a number of factors including:

- Risk management considerations
- Physical management requirements
- Potential for attack by pests or disease
- Suitability and appropriateness for the proposed planting site
- Potential to contribute to the landscape
- Tree behavioural characteristics (including leaf fall volume and propensity to drop limbs)
- Potential effect on existing Council and private assets (including footpaths and fences, kerb and channel, stormwater drainage and road surface)

The urban tree canopy will be maintained with the implementation of a strategic replacement program in accordance with developed tree programs.

Council will consider existing trees when considering applications for new development. Where appropriate, trees will be protected from development and other activities that threaten their health.

The conflicting requirements of trees and infrastructure will be minimised where possible. Council will consider a number of options including; the relocation or reconfiguration of infrastructure and removal of the tree to reduce the need for excessive pruning.

The community will be educated, consulted and informed about major tree management projects, and the need to effectively manage trees.

Historically Significant trees will be managed as far as practical to ensure preservation.

Catchment management principles will be considered in the management of remnant urban bushland.



ROADSIDE MAINTENANCE – SPRAYING & SLASHING POLICY

COUNCIL POLICY	
Effective Date:	21/09/1999
Last Review:	10/02/2003
Current Review:	October 2013
Adopted by Council:	
Next Review Date:	
Responsible Officer	Director Asset Services

POLICY STATEMENT

The purpose of this Policy is to define Council's objective with respect to the reduction of grass and weeds growing on Local Roads reserves, by slashing and spraying. The benefits of this policy will include a reduction in fire fuel, improved drainage of the road formation and consequently assists in prolonging the life of our roads and improved sight distance in situations such as intersections and curves.

POLICY APPLICATION

This Policy applies to all local road reserves within the Shire of Strathbogie.

Distribution of Roadside Grass and Weeds

Rural Roads

The Shire is basically divided into two geographical areas by the Hume Freeway.

To the south of the Hume Freeway is undulating and hilly country with generally narrow road reserves. Scrub and bush grows to the edge of the road formation with some weeds.

To the north of the Hume Freeway there is generally open grassland with some treed areas, offering room for a great amount of exotic grasses such as phalaris and wild oats.

Urban Areas

Urban areas naturestrips are generally maintained by adjoining landowners.

If not maintained, Council will slash once per year for fire fuel reduction purposes prior to the start of the designated fire-season. The naturestrip is defined as the area that extends from the property line to the roadside drain whether it is kerb and channel or open drain.

Control of grass growing between the drain and the road surface is the responsibility of Council.

Noxious Weeds

Noxious weeds are divided into 4 categories:

1. State Prohibited,
2. Regionally Prohibited,
3. Regionally Controlled &
4. Restricted. Category

Category 1 & 2 weeds are the more important weeds and on Local Roads is the responsibility of Department of Environment and Primary Industry. Most noxious weeds on Local Roads fall into the category 3. These weeds are the responsibility of the adjacent landowner or leasee.

Noxious weeds within townships are the responsibility of the adjacent landowner except for the declared main road network (listed below), which are the responsibility of VicRoads or the Council (within town boundaries).

Main Roads

- Euroa Mansfield Road
- Euroa Main Road
- Euroa Shepparton Road
- Avenel Nagambie Road
- Heathcote Nagambie Road
- Dookie Violet Town Road
- Murchison Violet Town Road

Assessment of Works

The growth of weeds and grass is generally seasonal. The Council's road maintenance plan requires routine inspection by the maintenance contractor. Results of inspection and reports from the public will be considered and assessed for action.

Control of Roadside Grass and Weeds

In accordance with the Municipal Fire Management Plan, Council reduces roadside fire fuel quantities along Primary and Secondary Fuel Reduced Corridors.

Spraying

Spraying of roadsides is an integral part of roadside vegetation control.

Spraying will be undertaken when deemed appropriate to achieve maximum effectiveness for weed control. This timing will generally be in the period late winter-early spring for general roadside spraying.

Area of Roadside Sprayed

Roadsides are sprayed in accordance with Council's Service Management plan. The width will usually include the shoulder, roadside furniture (guideposts) and part of the table drain.

Spraying Intersections

Significant intersections will generally be sprayed the full width of the road reserve for a distance of generally 40m from the intersection. The actual extent of spraying will depend on roadside growth, road reserve width, other vegetation on the reserve or adjoining private property and the "sight-line" warrants necessary for "Give Way" signs (if applicable). The area to be sprayed is generally defined by difficulty of slashing, taking into account drain location etc.

Areas Not To Be Sprayed

Some areas will not be sprayed for environmental reasons. These areas include environmentally sensitive areas such as where significant or rare native flora exists, some agricultural practices are apparent ie. vineyards, the land occupier maintains the roadside, or the area is densely populated.

Chemical Used in Roadside Spraying

Environmentally friendly Glyphosate (Roundup) is the only chemical to be used for general roadside spraying under this policy, unless otherwise approved by the Director, Asset Services.

Other Chemicals Used

Some weeds will require special chemicals other than Glyphosate. All chemicals are to be used strictly in accordance with the manufacturer's recommendation.

Quality of Personnel

Spraying operations will only be performed by qualified personnel, trained in the use of herbicides.

Slashing

Slashing will be used late in the growing season where appropriate. Slashing is also used in environmentally sensitive areas.

Member of Public – Roadside Mowing

Under Road Management (Works and Infrastructure) Regulations 2005 Section 12, a person may mow any part of a roadside without written consent from the co-ordinating road authority.



ROADSIDE FATALITY MEMORIALS POLICY

COUNCIL POLICY	
Effective Date:	17/12/2002
Last Review:	
Current Review:	October 2013
Adopted by Council:	
Next Review Date:	
Responsible Officer	Director, Asset Services

STATEMENT OF POLICY

The purpose of this policy is to set guidelines for the establishment and maintenance of roadside fatality memorials.

POLICY APPLICATION

Definition

A **roadside fatality memorial** is any object constructed, erected or placed on the road within the road reserve to commemorate/indicate a road fatality. Memorials may include items such as wooden crosses, coloured posts, flowers or any type of construction with or without plaques or inscriptions.

Statement of Commitment

Strathbogie Shire Council recognizes that some members of the community wish to mark the location of a fatal crash on the Council's local road network by the establishment of a roadside memorial. However, the Council will not permit the establishment of new roadside fatality memorials on the Council's local road network.

REQUIREMENTS AND PERFORMANCE STANDARDS OF EXISTING MEMORIALS

In dealing with existing roadside fatality memorials, the following requirements will be addressed:

Location

The memorial shall be located in a position where it will not distract drivers' attention from the driver task, or interfere with the role of any traffic control item.

The memorial shall be located in a position where it will not be hazardous to passing traffic, or prevent appropriate maintenance of the road reserve. The VicRoads Clear Zone Guidelines should be used as a guide in the assessment.

Other

Any objection or complaint from nearby residents or from road users regarding any aspects of memorials, including the activity of visitors to the memorial, shall be carefully considered and if necessary the memorial shall be relocated or removed. All costs associated with the performance of these works shall be borne by the parties responsible for the establishment of the memorial.

The Strathbogie Shire Council will not accept any responsibility whatsoever for the maintenance of memorials, or any loss, damage, removal or relocation of roadside fatality memorials that may occur due to road maintenance or construction activities.



TOTAL ASSET MANAGEMENT POLICY

COUNCIL POLICY	
Effective Date:	17/12/2002
Last Review:	15/11/2011
Current Review:	October 2013
Adopted by Council:	
Next Review Date:	
Responsible Officer	Director, Asset Services

POLICY STATEMENT

The purpose of this policy is to outline the framework for the management of physical assets (Assets) within the Strathbogie Shire.

The management of all Assets will be performed in a structured and co-ordinated way.

This policy will apply to all Assets either owned by, or under the control of, the Strathbogie Shire Council.

This Policy is directly related to and supports the Council Plan and the Long Term Financial Plan.

Vision:

The Strathbogie Shire Council has the following vision for the management of Assets:

The Strathbogie Shire Council meets its community needs by managing Assets within a strategic framework, using best appropriate practice to achieve maximum effective life, best community outcomes and inter-generational equity.

Organisation Goals for Asset Management:

The Strathbogie Shire Council recognises, and believes, that the on-going and proper management of Assets is vital for the long term well-being and sustainability of the municipality.

Sound Asset management involves a whole of organisation approach. The 2013-2017 Council Plan identified as one of its Goals:-

- A safe, connected Asset network that responds effectively to community needs. Ensure the Shire's infrastructure enhances efficiency for people and freight movement, service delivery and community amenities (infrastructure).

The Objective is:

- Provide well maintained, affordable and appropriate infrastructure.

The relevant Strategy associated with Asset Management is:

- Provide best practise asset management

GOALS FOR ASSET MANAGEMENT

Strategy:

This objective will be achieved through the development of a Total Asset Management Strategy for the strategic management of all Council Assets: includes Land, Buildings & Structures, Transport, Bridges, Open Space, Water, Plant & Equipment, Furniture and Fittings and Cultural.

The System will be based on the on-going development and operation of a suite of asset management plans for each group of Council Assets, as above, subordinate to an overarching Asset Management Plan.

POLICY APPLICATION

The management of Council Assets is based on a life-cycle-cost approach. Life-cycle-cost asset management is defined as the time interval between the recognition of a need, or an opportunity, through to the creation of an asset and to its final disposal. The objective of this approach is to look at the best overall long term cost/ benefit when making asset management decisions.

At a strategic level, Council will include responsible asset management as a key consideration in its long term financial planning and the development of the Council Plan, incorporating the Strategic Resource Plan.

The life-cycle approach of asset management includes the following steps:

- **Asset planning** – involves confirming the service that is required and ensuring that the proposed Asset is the most effective solution to meet the customer's need, as per departmental Service Plans.
- **Asset creation/acquisition** – is the provision of, or improvement to, an Asset.
- **Asset financial management** – requires the recognition of all costs associated with Asset ownership, and supports cost-effective decision-making.
- **Asset operations** – this function relates to the day-to-day running of Assets.
- **Asset maintenance** – this function relates to the day-to-day upkeep of Assets.
- **Asset condition/performance monitoring** – where the asset's performance relates to the ability of the asset to meet the target levels of service whilst Asset condition reflects the physical state of the Asset. Monitoring Asset condition and performance throughout the asset life-cycle is important in order to identify under-performing Assets or those which are about to fail.
- **Asset renewal/refurbishment** – is the significant upgrading of an Asset, or a component, to restore the Asset to its original functional condition and performance.
- **Asset upgrade** – is the replacement of an Asset, with an enhanced item
- **New Asset**—is the provision of an item which did not previously exist.
- **Asset disposal/rationalization** – When an Asset is no longer required, becomes uneconomic to maintain or rehabilitate. This step provides an opportunity to review the need for the asset in its current configuration or condition.
- **Asset management audit/review** – performing regular internal and external audits ensures a continuous Asset management improvement cycle, and assists in achieving best appropriate practice.

Asset Management Plans are built up from the above steps, and take account of, the following factors:

Demand and Community Expectation:

The Council will assess community demand and expectation in accordance with Best Value Victoria principles, which are:

- All services provided by a Council must meet the requirements for quality and cost standards established by Council.
- All services provided by Council must be responsive to the needs of its community.
- Each service provided by Council must be accessible to those members of the community for whom the service is intended.
- Council must achieve continuous improvement in the provision of service for its community.
- Council must develop a program of regular consultation with its community in relation to the services it provides.
- Council must report regularly to its community in its achievements in relation to the above principles.

Capital investment and Lifecycle Costing:

- All Assets will be managed from a lifecycle perspective in accordance with the relevant sections of the Total Asset Management Plan.
- Appropriately audited preventive maintenance program will be developed for all Assets to ensure that the lowest lifecycle cost is achieved and asset value/condition is maintained.
- Capital investment proposals, including grants from all sources, will be evaluated, prioritised and selected, in accordance with adopted Capital Works Evaluation Framework criteria, as per Total Asset Management Plan, which will include a whole of Council cost-benefit analysis, for both renewed and new assets.
- In order to address the Infrastructure Renewal Gap, Council will aim to apply at least 85% of capital works budget to Renewal/ Refurbishment, 10% to Upgrade/Improvement and 5% to New/Expansion. This Policy aspect should be read in conjunction with the Long Term Financial Plan.

Asset Operations and Maintenance:

- Maintenance plans will be designed using best available analysis techniques, as appropriate, and shall incorporate a benefit-cost approach.
- Council will regularly review all asset maintenance and lifecycle management techniques being undertaken to ensure the Council is adopting best appropriate practices.
- Council will apply a 'renew before new' philosophy by applying robustly calculated asset renewal funding demand to the long term financial plan for consideration as a non discretionary budget item.

Asset Accounting and Costing:

- The Council will keep detailed Asset registers on all Assets owned by it, or under its control.
- Economic lives will be given to each of these assets, with the written down value and depreciation value, determined in accordance with the current applicable accounting standards.

- Asset Renewal Demand will be calculated with a method that reflects the true consumption/Depreciation of the asset and provide an indication of the future cash flows necessary to sustain asset condition and maintain required service levels.
- The Council will determine the cost of service delivery on a full cost-recovery basis.

Risk Assessment and Management:

- Risk assessments are to be completed for all capital projects.

Total Asset Management Plan (TAMP):

- The Council will develop a Total Asset Management Plan (TAMP), which will apply to all the Asset groups under the care and control of the Council, as detailed in the table below.
- The development of the TAMP will be governed by community consultation outcomes and local government financial reporting requirements.
- The TAMP will include a total life cycle cost approach from Asset needs identification and concept definition through to asset disposal.
- The TAMP will be subject to a disciplined, continuous audit and improvement program.

Data Management:

- Responsibility for data accuracy and currency rests with the relevant Manager.
- Data will be audited periodically to ensure compliance with Council policies and procedures and Australian Accounting Standards.
- Data will be recorded on Councils Asset Management System, in a timely manner and linked to Geo-spatial Information System (GIS).

Skills & Processes:

- Councillors and staff, with asset and financial management responsibilities, are to be trained in relevant asset and financial management principles, practices and processes.
- A skills assessment will be undertaken to identify any gaps and the associated training required.
- All Asset expenditure will be accounted for in the relevant specific expenditure categories of operations, maintenance, renewal/refurbishment, upgrade/improvements, new/expansion and that financial reporting is capable of detailing these categories in outputs.

POLICY IMPLEMENTATION

This policy will be implemented through the creation, as required from time to time, of cross-functional teams to consider the next relevant step in the Asset Management process.

Council will establish and maintain a cross-functional Asset Management Steering Group to oversee Asset Management responsibilities and to coordinate, advise on and facilitate the implementation of the adopted Asset Management Strategy.

The attached matrix, exhibit 1, provides an indication of the relevant directorates that are considered to have input into the various steps within the complete Asset Management process for the various Asset Groups.

Existing Total Asset Management Plan (TAMP) will be revised every three years. This requirement will be the responsibility of the Director Asset Services. The revisions will include an updated financial forecast based on the existing Asset condition. The revision will also include an Improvement Plan to ensure the quality and reliability of the information provided by the TAMP.

Council will implement a robust Total Asset Management System that will include an Asset Register with a link to Councils GIS system, customer service module, works management module, mobile computing, Asset condition assessment, and Asset valuation. This will allow operations/maintenance information to be fed forward into the overall decision-making process.

Council will conduct regular condition assessments of all Asset groups. The frequency of the condition assessments will be a maximum of 5 years and the next assessment dates will be no later than the dates shown in the table below:

Item No:	Asset Group:	Asset Category:	Assessment Frequency:	Assessment Due:
1	Transport	Roads, Paths, Kerb & Channel, Car Parks, Runways & Helipads, Traffic Control, Boat Ramps & Jetties.	3 years	Dec 2014
2	Bridges	Bridges, Major Culverts.	3 years	Dec 2014
3	Water	Strom Water Drainage, Flood Control, Water Supply & Storage, Waste Water.	5 years	Dec 2013
4	Land	Land Under Roads, Easements, Freehold	5 years	Dec 2013
5	Building & Struct.	Buildings, Swimming Pools	5 years	Dec 2017
6	Open Spaces	Ovals & Courts, Play Spaces, Landscaping, Open Space Amenities, Lighting, CCTV, Audio, Fencing & Gates, Trees.	5 years	Dec 2017
7	Plant & Equip.	Plant & Equip., Furn. & Office Equip., Software.	5 years	Dec 2013
8	Cultural	Monuments, Statues, Fountains, Artwork.	5 years	Dec 2013

The new asset condition assessment information will be used to develop and refine the asset degradation curves, which will increase the Councils knowledge of the Asset base. The degradation curves are used to assess Asset consumption and depreciation as well as providing a better estimate of real Asset life. Regular condition assessments will provide one measure, over the longer term, of the Councils performance in managing community Assets.

Council will regularly consult with and survey the community using a variety of appropriate techniques to gain an understanding of the communities expectations on services provided, and service levels. This work will be performed in accordance with the Best Value Victoria principles.

Related Documents:

- Strategic Longer Term Plan (Council Plan).
- 10 Year Long Term Financial Plan.
- Asset Management Strategy.
- Council Policy Protocol.
- Risk Management.
- Budget Preparation and Financial Reporting.
- Municipal Strategic Statement

Review:

This policy will be reviewed two years from the date of adoption, with operational amendments as required in accordance with Council approval.

Responsibility for managing a review rests with the Manager Engineering. The review will be undertaken by the Asset Management Steering Group based on industry requirements and feedback on the effectiveness of the policy in achieving its objectives which will then be provided to Council.

Exhibit 1

STRATHBOGIE SHIRE COUNCIL

Asset Management: -- Asset Group/Responsibility Matrix

Item no:	Asset Group	Who has responsibility for the following asset management activities:									
		Planning	Creation/ Acquisition	Financial Mgmt	Operations	Maintenance	Condition/ Performance	Rehab./ Renewal	Replacement	Disposal/ Rationalisation	Audit/ Review
1	Transport	AS/CCS/DS	AS/CCS/DS	AS/CCS	AS	AS	AS	AS	AS	AS/CCS/DS	AS/CCS
2	Bridges	AS/CCS/DS	AS/CCS	AS/CCS	AS	AS	AS	AS	AS	AS/CCS/DS	AS/CCS
3	Water	AS/CCS/DS	AS/CCS	AS/CCS	AS	AS	AS	AS	AS	AS/CCS/ DS	AS/CCS
4	Land	AS/CCS/DS	AS/CCS	AS/CCS	AS	AS	AS	AS	AS	AS/CCS/ DS	AS/CCS
5	Buildings & Structures	AS/CCS/DS	AS/CCS	AS/CCS	AS	AS	AS	AS	AS	AS/CCS/ DS	AS/CCS
6	Open Space	AS/CCS/DS	AS/CCS	AS/CCS	AS	AS	AS	AS	AS	AS/CCS/ DS	AS/CCS
7	Plant & Equipment	AS/CCS/DS	AS/CCS	AS/CCS	AS	AS	AS	AS	AS	AS/CCS/ DS	AS/CCS
8	Cultural	AS/CCS/DS	AS/CCS	AS/CCS	AS	AS	AS	AS	AS	AS/CCS/ DS	AS/CCS

***Notes:**

AS = Asset Services

Directorate

DCCS = Corporate and Community Services

Directorate

DS = Sustainable Development Department



VEHICLE CROSSING TO ACCESS PRIVATE LAND FROM A PUBLIC ROAD POLICY

COUNCIL POLICY	
Effective Date:	20/04/2004
Last Review:	15/08/2006
Current Review:	October 2013
Adopted by Council:	
Next Review Date:	
Responsible Officer	Director, Asset Services

POLICY STATEMENT:

The purpose of this policy is to define Strathbogie Shire Council's requirements for the construction and maintenance of vehicle crossings to access private property from a public road.

POLICY APPLICATION:

This policy applies to all public roads within the Shire of Strathbogie for which the Strathbogie Shire Council is the Coordinating Road Authority and/or the Responsible Road Authority.

General:

Landowners intending to construct a vehicle crossing from a public road to their property must obtain a Vehicle Crossing Permit from the Council, prior to the construction of the crossing. The landowner must construct and maintain the vehicle crossing in accordance with the requirements of this Policy, Vehicle Crossing Permit conditions, and the relevant Local Laws.

The Strathbogie Shire Council has developed standard drawings for the construction of vehicle crossings to access private property from public roads.

These standards are aimed at raising the levels of general road safety on our roads, reducing risk for the road user, balancing risk and cost for the landowner, improving the service life of crossings, and improving the amenity of the area.

Landowners seeking to install an alternative vehicle crossing design will submit fully certified engineering computations and drawings to the Council for consideration. The submitted computations, and plans, must be certified by a suitably qualified Civil Engineer. Council is under no obligation to accept the submitted plans.

All new vehicle crossings and any works on existing vehicle crossings, require a vehicle crossing permit from Council prior to commencement of works, and must be constructed and maintained in accordance with Council's requirements.

Vehicle Crossing Siting Requirements:

Vehicle crossings must be located to minimise road safety risks. Consideration shall be given to a number of factors in determining a suitable location for the any proposed crossing, including:

- Sight distance from the proposed crossing along the road to be entered
- Existing vegetation, and extent of vegetation that may need to be removed/trimmed
- Drainage requirements of the site
- Gradient of the proposed crossing
- Proximity of proposed crossing to an intersection

Vehicle Crossing Construction Standards:

‘Culvert’ type and open drain vehicle crossings:

Where the depth of the table drain at the proposed vehicle crossing location is less than 150mm deep, as shown on Council’s standard drawing SSC-SD3, and is highly likely to remain at less than 150mm for the life of the vehicle crossing, then a culvert or pipe is not necessary. In these situations, the vehicle crossing must not impact on the level of the road shoulder.

Fire Access tracks, Class 0 and Class 1 roads are to be constructed to comply with Council’s standard drawing SSC-SD3, without the requirement for driveable end walls, unless an alternative vehicle crossing design has been approved for the site by Council.

Where culvert type vehicle crossings are required on Class 2, Class 3 and Class 4 roads, they are to be constructed to comply with Council’s standard drawing SSC-SD3, unless an alternative vehicle crossing design has been approved for the site by Council.

‘Kerb and Channel’ type vehicle crossings:

Where existing kerb and channel is present, or is required as part of a development, vehicle crossings are to be constructed to comply with Council’s standard drawing, SSC-SD1 for residential sites, and SSC-SD2 for industrial sites, respectively.

Vehicle Crossing Maintenance:

The landowner of the property served by the vehicle crossing is responsible for the management, maintenance and/or replacement of the vehicle crossing. The landowner is responsible for maintaining the crossing in a safe condition at all times.

If the Council determines that a vehicle crossing is not maintained in an acceptable condition, it will advise the landowner, in writing, that the vehicle crossing requires works to restore it to a safe condition. The landowner will undertake the necessary works to ensure that the vehicle crossing is repaired, renewed or replaced so that it is safe. These costs will be borne by the landowner. If the landowner does not repair the crossover in a reasonable time, Council may undertake the required works at the expense of the landowner.

Council will contribute to the repair, renewal and/or replacement of a vehicle crossing if it is clearly determined that a Council asset has contributed to the unsafe condition of the vehicle crossing. The amount of the contribution by Council will be determined by agreement between the landowner and the Council. Failing agreement, the cost will be shared on a 50:50 basis.

The landowner must maintain the crossing so that it remains serviceable and does not impede the drainage along the road drain.

Limits of responsibilities for vehicle crossings:

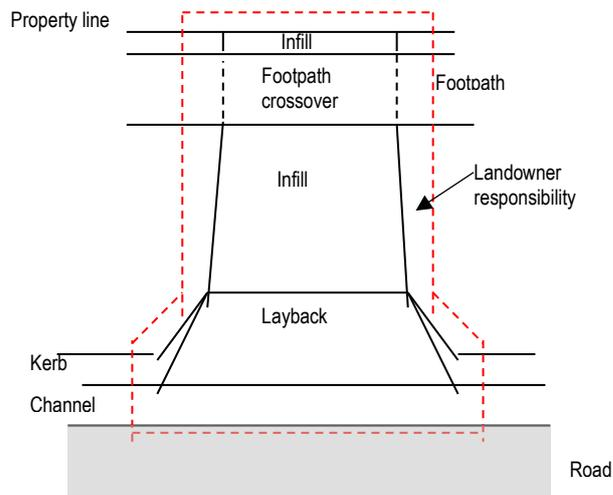

Figure 1: Vehicle Crossing Responsibility: - Kerb and Channel

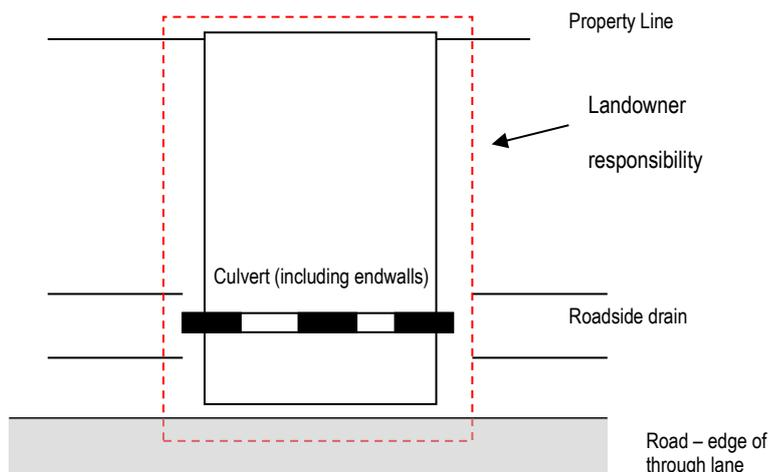

Figure 2: Vehicle Crossing Responsibility: – Culvert crossing

Council Rehabilitation and/or Upgrade works:

If Council undertakes Rehabilitation and/or Upgrade works on roads that will result in the need to realign, or alter an existing vehicle crossing, the cost of replacement of the vehicle crossing will be included in the overall project costs.

Policy Implementation:

This policy will be implemented across the whole of the municipality.

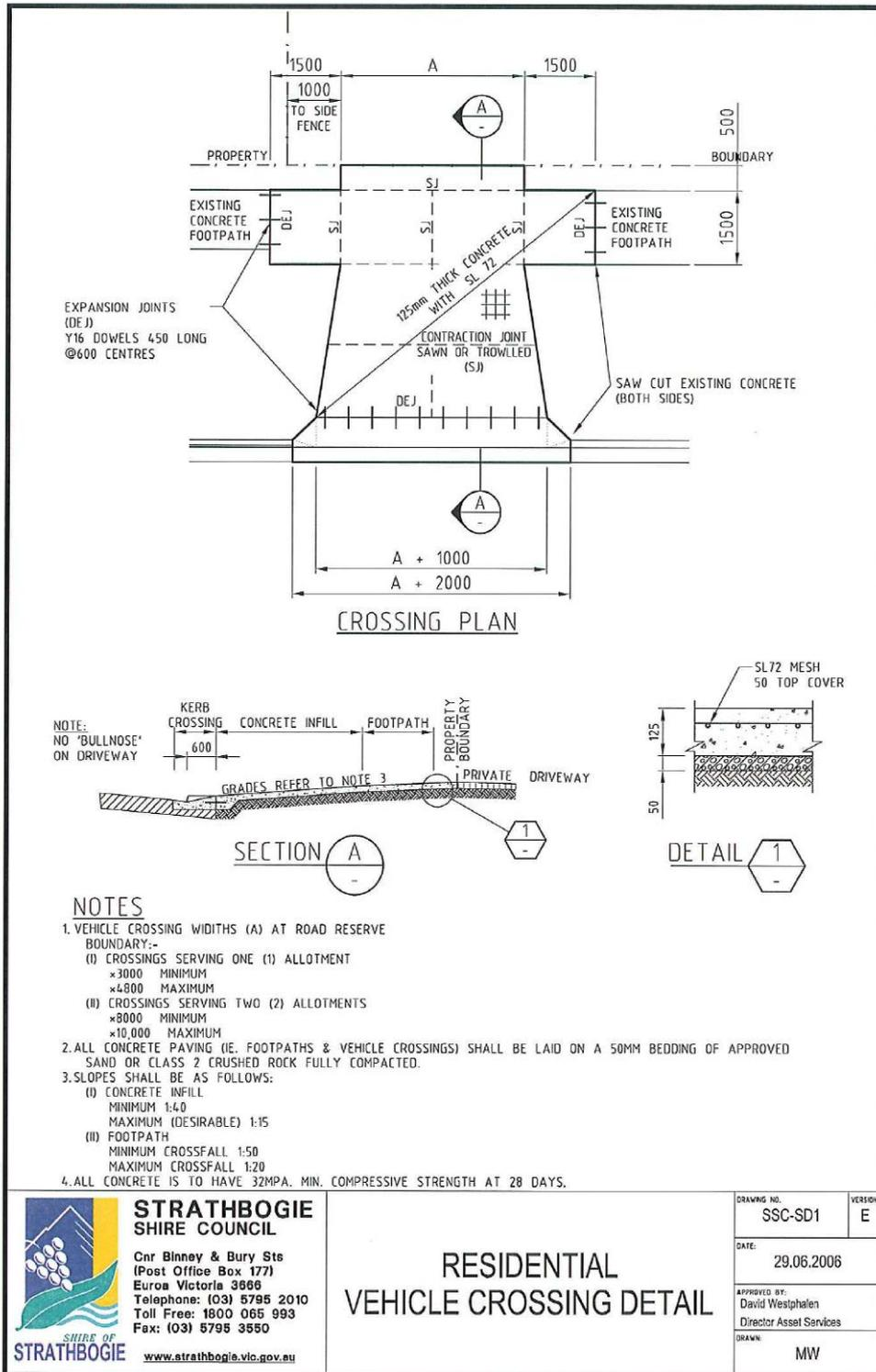

STRATHBOGIE SHIRE COUNCIL
 Cnr Binney & Bury Sts
 (Post Office Box 177)
 Euroa Victoria 3666
 Telephone: (03) 5795 2010
 Toll Free: 1800 065 993
 Fax: (03) 5795 3550
www.strathbogie.vic.gov.au

**RESIDENTIAL
VEHICLE CROSSING DETAIL**

DRAWING NO. SSC-SD1	VERSION E
DATE: 29.06.2006	
APPROVED BY: David Westphalen Director Asset Services	
DRAWN: MW	

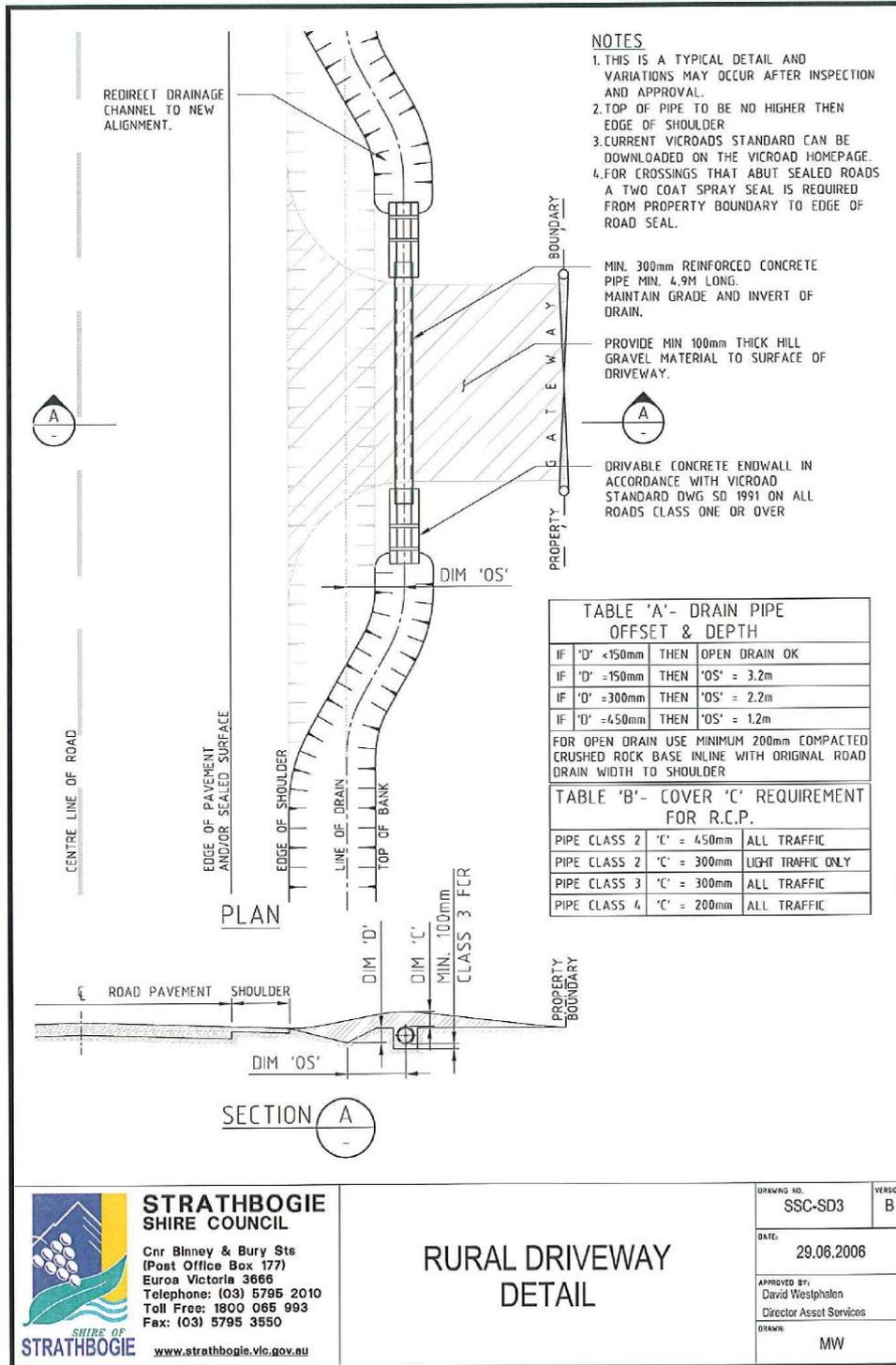

STRATHBOGRIE SHIRE COUNCIL
Cnr Blinney & Bury Sts
(Post Office Box 177)
Euroa Victoria 3666
Telephone: (03) 5795 2010
Toll Free: 1800 065 993
Fax: (03) 5795 3550
www.strathbogrie.vic.gov.au

**RURAL DRIVEWAY
DETAIL**

DRAWING NO.	SSC-SD3	VERSION	B
DATE:	29.06.2006		
APPROVED BY:	David Westphalen Director Asset Services		
DRAWN:	MW		

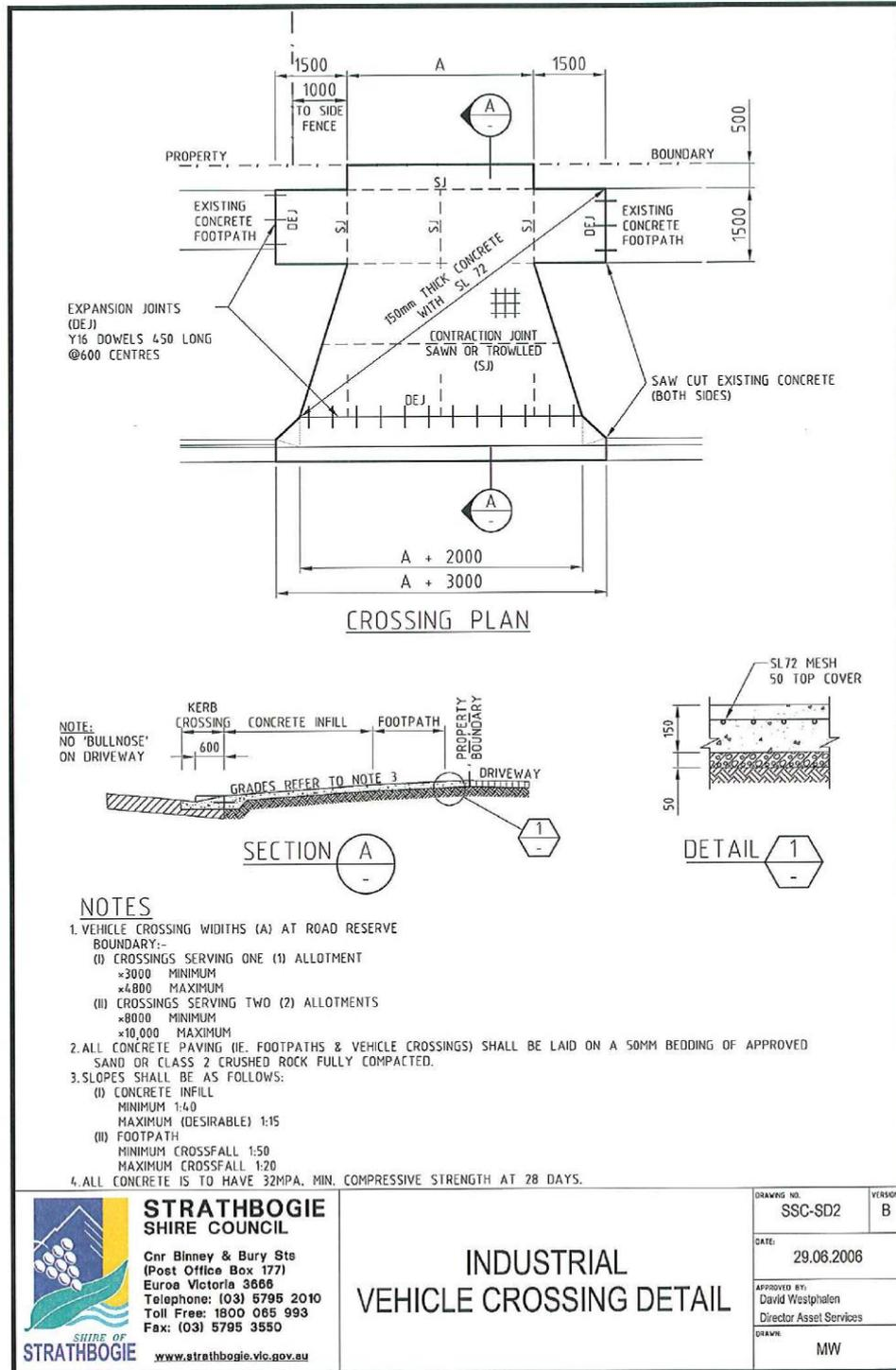



PUBLIC ROAD REGISTER POLICY

COUNCIL POLICY	
Effective Date:	20/04/2004
Last Review:	20/04/2007
Current Review:	October 2013
Adopted by Council:	
Next Review Date:	
Responsible Officer	Director Asset Services

POLICY STATEMENT

The purpose of this policy is to define the roads that the Strathbogrie Shire Council will maintain in accordance with the Council's Road Management Plan.

The Policy outlines the criteria to be met for a road to be included on the Council's Public Road Register.

POLICY APPLICATION

This policy applies to all roads within the Shire of Strathbogrie

PUBLIC ROAD REGISTER

The Road Management Act requires that a road authority (the Council) must keep a register of public roads.

The Council must register on its register of public roads a road in respect of which the Council has made a decision that the road is reasonably required for general public use.

Roads that are not included on the road register will not be maintained by the Council.

“Reasonably required for general public use”:

To be included on the register of public roads, a road must meet the following criteria in order to be deemed to be “reasonably required for general public use”:

- be a public highway
- the Council must be deemed to be the coordinating road authority
- the road reserve boundaries must be fenced
- the road is free of gates and/or grids
- the road relates to a council owned asset such as a pathway, a shared footway or a park
- the road provides access to a full-time occupied residence (public roads that provide alternate or secondary access to a residence may not necessarily be included on the register)
- the road provides access to at least three farm properties (public roads that provide alternate or secondary access to a property may not necessarily be included on the register)
- subdivisional roads that have been designed, and constructed to Council's design and construction parameters, and have been accepted by Council at the end of the defects liability period
- if the road reserve boundaries are not fenced, and the road is not clear of gates and/or grids, the road may be considered to be a strategic fire access track under Council's Municipal Fire Prevention Strategy, and subject to upgrading works funded by the Country Fire Authority (CFA)

Roads that are registered on the public road register will be maintained in accordance with the Council's Road Management Plan.

The road register will be reviewed at least annually, at the time of review of the Road Management Plan.

POLICY IMPLEMENTATION:

This policy will be implemented across the whole of the municipality.



PLAYGROUNDS MANAGEMENT POLICY

COUNCIL POLICY	
Effective Date:	18/05/2004
Last Review:	
Current Review:	October 2013
Adopted by Council:	
Next Review Date:	
Responsible Officer	Director, Asset Services

POLICY STATEMENT:

The purpose of this policy is to define the Strathbogie Shire Council's approach to management of its playgrounds.

POLICY APPLICATION:

This policy applies to all playgrounds within the municipality under the control of the Council.

GENERAL

The Strathbogie Shire Council is the responsible authority for a large number of playgrounds that are located throughout the municipality.

Playgrounds must be managed in a systematic manner, in accordance with Council's Asset Management Policy, and general asset management principles.

The following are the key principles that define the Strathbogie Shire Council's Playground Management Policy:

- Council is the controlling authority of its playgrounds, and will decide which playground equipment is purchased and installed in any of playgrounds it controls.
- The primary focus of playground management is safety and risk management
- Council will manage its playgrounds in accordance with the relevant Australian Standards, and asset management principles and practices.
- Council will develop a playground management plan for the implementation of this policy, and the strategic and operational management of the playgrounds.
- Council will develop a hierarchical system for its playground asset base. This hierarchy will be used in the playground asset management process.
- Council will only purchase and install, or allow to be purchased and installed in its playgrounds, playground equipment that complies with the relevant Australian Standards.
- All playground equipment to be installed in Council's playgrounds will be installed by the equipment manufacturers installation team, and certified by the manufacturer that the equipment has been installed correctly.
- No new playgrounds will be established until the current playground asset base is effectively managed, and satisfy the requirements of the relevant Australian Standards
- Council will regularly review its playground asset base, and the need for upgrading, enhancement and rationalization of that asset base.
- Council will consult with relevant stakeholders on playground asset management issues.
- Council will, on a regular basis, have a condition assessments performed on its playground asset base by a suitably qualified external consultant to ensure an independent assessment of Council's playground management practices

POLICY IMPLEMENTATION:

This policy is implemented through the Strathbogie Shire Council's Playground Management Plan.

The Playground Management Plan was adopted by Council on February 20, 2007.



ROAD NAMING POLICY

COUNCIL POLICY	
Effective Date:	20/07/2004
Last Review:	
Current Review:	October 2013
Adopted by Council:	
Next Review Date:	
Responsible Officer	Director, Asset Services

POLICY STATEMENT

The purpose of this policy is to define the process by which roads are named within the Shire of Strathbogrie.

POLICY APPLICATION

This policy applies to all existing and/or proposed roads within the Shire of Strathbogrie.

Policy Authority

The naming of roads is the responsibility of Local Government under Section 206 of the Local Government Act 1989.

Policy Objective

The key objective of this policy is to provide names where required for all roads within the Shire.

General

Road name changes occur for a variety of reasons including subdivision, change of circumstances or clarification to remove duplication or ambiguity. They may be initiated by either Council or the public.

Well signposted, clear and unambiguous road names are important for our community as they allow for the effective and efficient provision of Council and other services to the community. Particularly relevant in this context are emergency services.

The Guidelines for Geographic Names upon which the existing Road Naming Policy is based were created in October 2004 under the Geographic Place Names Act 1998.

They were revised in July 2010 after detailed consultation with municipal councils, government departments, the public, emergency response service providers and public service providers. They are based on national standards and policies and provide a strong basis for standardised and unambiguous naming procedures across the State. They are mandatory for naming authorities in Victoria

Principles

There are sixteen core principles identified in the Guidelines

- A. Language;
- B. Recognising the public interest
- C. Ensuring public safety;
- D. Ensuring names are not duplicated;
- E. Directional names to be avoided;
- F. Assigning extent to a feature, locality or road;
- G. Linking the name to the place;
- H. Using commemorative names;
- I. Using commercial or business names;
- J. Names must not be discriminatory;
- K. Recognition and use of Indigenous Australian names;
- L. Dual names;
- M. Consulting with the public;

- N. Lodging, considering and addressing objections
- O. Notification of a naming decision; and
- P. Signage

The detail of these principles is contained in the Guidelines. It should be noted that although the Guidelines specify 30km for rural duplication, Council has set a distance of 50kms.

Specific Road Naming Principles

There are seven principles specific to road naming

- A. AS/NZS Standard 4819:2011 - Rural and Urban addressing;
- B. Extent: road course, start and end points;
- C. Addressing and numbering;
- D. Road types;
- E. Unacceptable road names;
- F. Obstructed or altered roads; and
- G. signage.

The detail of these principles is contained in the Guidelines.

Procedures

The procedure for naming existing named/unnamed roads is broadly as follows:

- a. Proposed road name checked for compliance with Guidelines for Geographic Names and approved by Office of Geographic Names;
- b. Name considered by committee of officers representing relevant Council departments;
- c. List of acceptable names referred to Councillors for consideration;
- d. Approved names reported to Council for consideration;
- e. Council approved proposals advertised publicly and adjoining owners notified in writing, seeking submissions under Section 223 of Local Government Act;
- f. Written submissions dealt with by Section 223 Committee;
- g. Recommendations reported to Council;
- h. Office of Geographic Names advised of Council decisions for ratification;
- i. Names gazetted;
- j. Public, adjoining owners, service authorities and Council officers notified; and
- k. Signage ordered and installed.

The procedure for new names in a subdivision is determined by reference to the Guidelines and negotiations with the respective developers. Addresses of properties within a subdivision are required as part of the planning process and protected by a statutory declaration before compliance.

Public Road Register

In accordance with the Road Management Act 2004, Council is required to maintain a Register of Public Roads. All roads appearing in the Register should be named. Whenever a road is named/renamed the Register must be amended accordingly.

Signage

To comply with the intent and purpose of this policy all named roads must be signed. Road name signage must comply with the requirements of the relevant Australian and New Zealand Standards.

Policy Clarification

This policy is based on the principles and policies spelt out in Guidelines for Geographic Names 2010 and where clarification is required on any matter the Guidelines shall be the reference point.

Policy Implementation

This policy will be implemented upon adoption by Council.



SPECIAL RATE AND CHARGE SCHEME POLICY

COUNCIL POLICY	
Effective Date:	15/02/2005
Last Review:	
Current Review:	October 2013
Adopted by Council:	
Next Review Date:	
Responsible Officer	Director Asset Services

POLICY STATEMENT

This policy is designed to assist Council and its residents develop a built environment that meets the community's needs for access, amenity and safety. This policy operates within a legislative framework that recognizes that there is a responsibility on those deriving a special benefit from the development of infrastructure to contribute to its development and operation. Following construction, it is generally Council's responsibility to maintain the asset to the appropriate standard.

This policy is based on, and consistent with, the Ministerial Guideline about special rates and charges.

OBJECTIVES

The primary objective of this policy is to assist Council's residents develop appropriate local access infrastructure, including roads, footpaths and drainage (along with kerb and channel and underground drainage) to suit the community's current and future needs and desires.

Projected key outcomes of the policy are:

- minimal community conflict;
- open and transparent processes;
- fair and equitable costs apportionment;
- infrastructure in accordance with Council's Plan, and Council's Asset Management Plan, and complementary to the *Road Management Act* 2004.

Development of infrastructure in accordance with this policy will ensure that costs match results, and help Council and the local community to develop their asset responsibilities.

SCOPE

This policy applies to the development of works and services including roads, footpaths, kerb and channel, and drainage throughout the Shire.

DEFINITIONS

"**Ministerial Guideline**" refers to the Special Rates and Charges Ministerial Guideline - September 2004.

"**special benefit**" means a benefit that is additional to or greater than the benefit to other properties. While special benefits are considered to accrue to properties, the actual measurable benefits are provided to the owner and or occupiers of the properties. For example, an increase in a property's value is a special benefit.

"**special rate or charge scheme**" means a special rate or charge under section 163 of the Act.

Section 163(1) provides that a council may declare a special rate or charge (or a combination of both) for the purposes of

- defraying any expenses, or
- repaying any advance made to or debt incurred or loan raised by the council -

in relation to the performance of a function or the exercise of a power of the council, if the council considers that the performance of the function or the exercise of the power is or will be of *special benefit* to the persons required to pay the special rate or charge.

"The Act" means the *Local Government Act* 1989.

CONSULTATION

Council will consult with affected ratepayers prior to commencing the statutory process for the declaration of a special rate or charge.

Council will also, in accordance with sections 163 and 223 of the Act, consult in an open and honest manner with all ratepayers.

STATUTORY PROCEDURE

The requirements of sections 163 and 223 of the Act will be applied where a special rate or charge is to be declared. Following adoption by Council, a special rate and/or charge scheme shall be designed, tendered, constructed and finalized in the shortest practical time.

The statutory process involves -

- public notice about the proposed special rate or charge;
- notice to the persons who will be liable to pay the special rate or charge;
- an invitation to the public to make a submission about the proposed special rate or charge, along with the right to appear before a meeting of Council (or a committee); and
- consideration of any submissions made when deciding whether to proceed with the special rate or charge.

COUNCIL BUDGET

Council will make provision for special rates or charge schemes in its Annual Budget and forward Financial Plan. The allocation will be based on the projected program as endorsed by Council on an annual basis.

COSTS

Maximum levy

The Act restricts the amount Council may levy as part of a special rate or charge scheme.

Section 163(2A) provides that the total amount of the special rates and charges to be levied must not exceed the amount calculated in accordance with the formula -

$$R \times C = S$$

where -

R is the benefit ratio determined by the council in accordance with sub-section (2B);

C is the total cost of the performance of the function or exercise of the power under sub-section (1);

S is the maximum total amount that may be levied from all the persons who are liable to pay the special rates or special charges.

Sub-section 2(B) provides:

The benefit ratio is the estimated proportion of the total benefits of the scheme to which the performance of the function or the exercise of the power relates, including special benefits and community benefits, that will accrue as special benefits to all the persons who are liable to pay the special rates or charges.

The Ministerial Guideline sets out how to determine the benefit ratio (R) and the cost (C). In particular, the benefit ratio is to be calculated as follows:

= R

$$\frac{\text{TSB(in)}}{\text{TSB(in)+ TSB(out) + TCB}}$$

Where -

TSB (in) is the estimated total special benefit for those properties that the council proposes to include in the scheme.

TSB (out) is the estimated total special benefit for those properties with an identified special benefit that the council does not propose to include in the scheme.

TCB is the estimated total community benefit.

This formula will always result in an amount (S) less than the actual cost (C) where there exists a TSB (out) and/or TCB.

Apportionment

There is no one method for apportioning costs - that is, the criteria to be used as a basis for levying a special rate or charge.

However, Council is committed to ensuring that costs will be apportioned reasonably and equitably, and in accordance with the objectives in the Local Government Charter (Part 1A of the Act). In this context, equitably does not always mean equally.

There are a range of methods that can be used when apportioning costs. For instance, Council may apportion costs by developing special benefit units. It may also rely on land value, or land size. Often, where roads are involved the frontage of a property, along with land size, will be relied on.

Ultimately, the type of scheme involved will determine how Council will apportion costs in a special charge scheme.

OBJECTIONS

Any person may make a submission to Council when a special rate or charge is proposed - S223 (see above).

Further, where Council decides to levy a special rate or charge that exceeds two thirds of the total cost of the performance of the function or exercise of the power (s163B) -

- any person who is to be required to pay the special rate or charge, is entitled to object; and
- Council cannot make the proposed declaration if it receives objections from persons who will be required to pay the levy in respect of a majority of the rateable properties.

Where Council is to levy a special rate or charge under section 163B, Council will provide public notice about which persons may object, how to object, and that objection must be lodged within 28 days of the day on which the public notice is published.

RESPONSIBILITY

Assets Services Directorate



FIREARMS POLICY

COUNCIL POLICY	
Effective Date:	17/12/2007
Last Review:	16/09/2007
Current Review:	October 2013
Adopted by Council:	
Next Review Date:	
Responsible Officer	Director, Asset Services

POLICY

The Strathbogie Shire Council occasionally becomes involved in the destruction of animals that are seriously injured, sick or in situations where the behaviour of an animal poses a risk to the safety of the public or staff.

Some livestock owners and Officers appointed by various statutes have powers to destroy animals in given circumstances. These include Department of Primary Industry Inspectors, Victoria Police, Authorized Council Officers, RSPCA Inspectors and Veterinarians.

This policy provides that firearms may only be carried and used for Council related purposes by Council staff that are permitted to use a firearm in accordance with the *Firearms Act 1996* and other related legislation including the *Prevention of Cruelty to Animals Act 1986* and have been authorized to carry and use a firearm by the Chief Executive Officer. Approval to carry and use a firearm while on Council duty and for Council related purposes will be on the basis of either a general approval permitting day to day carriage and use of firearms on Council related duties (**General Firearm User**) or an approval for specific use authorized on a case by case basis (**Specific Firearm User**).

Legislative Requirements

The use of firearms in Victoria is governed by the *Firearms Act 1996 (Act)* and associated regulations. The provisions of the Act apply to all Council firearm activities including the possession, storage, carriage and use of firearms.

Approved Users

Eligibility and Approval Process

Council officers must meet the following criteria prior to be considered for authorization as a General Firearm User or a Specific Firearm User:

- Hold a current Class A and B Victorian Firearms Licence
- Have the means to carry a firearm in accordance with the Act

The Chief Executive Officer may appoint Council Officers as either a General Firearm User or a Specific Firearm User to enable Council to meet its obligations. Prior to being authorized as either a General Firearms User or a Specific Firearms User, the Council Officer must:

- Provide a copy of a Victorian current firearms licence
- Provide copies of firearm registration in their name for rifles of the appropriate calibre.
- Demonstrate that they can transport firearms in accordance with the Act by providing evidence that they have access to firearm container that meets the requirements of the Act.

Lapse of Approval

A Council Officer's authorization as a General Firearms User or a Specific Firearms User will lapse if any of the following occurs:

- The Officer's Victorian Firearms Licence lapses.
- The Officer is subject to a court order or injunction prohibiting the ownership or use of a firearm.
- The Officer ceases to be a Council employee
- The Chief Executive Officer at his sole discretion decides that Council does not require the Officer to be a General Firearms User or a Specific Firearm User.

Registration

The CEO will maintain a register of all General Firearms User and Specific Firearms User together with details of their licences, and firearms registrations. The register is to be reviewed annually in February.

Possession & Use

Carriage

A General Firearms User may possess a firearm at a Council work place for Council work related purposes.

A Specific Firearms User may only possess a firearm at work for work-related purposes when permission is granted from the Chief Executive Officer, or a Director for a specific task or function.

Discharge

Prior to using a firearm a General Firearms User or Specific Firearms User must, where practical and when safety or animal welfare is not compromised, ensure advice of intent to discharge that firearm is given to Victoria Police, and if on private property, to the owner or occupier of any private property on which the firearm is to be discharged.

Transportation & Storage

Firearms must be stored and transported at all times in accordance with the Act and associated regulations. Council does not provide facilities for the over night storage of firearms in Council buildings.

Should it be necessary to bring a firearm into a Council building, permission must be sought from the Chief Executive Officer, a Director or the person in charge of that building.



COUNCIL RESERVES AND FACILITIES POLICY

COUNCIL POLICY	
Effective Date:	15/02/2005
Last Review:	16/05/2006
Current Review:	October 2013
Adopted by Council:	
Next Review Date:	
Responsible Officer	Director, Asset Services

POLICY STATEMENT

The purpose of this policy is to establish Committees of Management for Council owned and controlled Reserves and Facilities and to provide a basis for their operations, risk management and relationship with Council.

POLICY APPLICATION

Committees of Management for Council owned and controlled Reserves and Facilities will be invited to enter into, and operate in accordance with, an Instrument of Delegation under Section 86 of the Local Government Act 1989 or a Licence Agreement for those Committees who remain an incorporated body.

Multiple users of a reserve and/or facility will be encouraged to form a Committee of Management which will comprise of a representative/s from each user group. Such users will enter into, and operate in accordance with, a Tenancy Agreement.

OPERATING PRINCIPLES

The Instrument of Delegation and Licence Agreement have been developed to accommodate the following underlying principles for the operation of Committees of Management:

- To promote optimal usage of facilities by the community.
- To delegate day to day operation to Committees of Management.
- To ensure that sound risk management practices are observed.
- To ensure that all users contribute to the maintenance and development of the reserve/facility for the long term benefit of the community.
- To provide for dealing with non-compliance disputes or changed circumstances with users.
- To ensure maintenance standards are consistent across the municipality, and that community assets are maintained to the highest possible standards within the constraints of Council /Community resources.
- To ensure that the use of the facility will be in harmony with & consistent with the reasonable expectations of the local community.
- To ensure that facility user groups will have open, non-discriminatory membership.
- To ensure that all facility users will be dealt with equitably.
- To support the promotion and development of youth activities.
- To operate in partnership with Council.

These principles allow the Committees of Management to operate in a manner which best responds to the needs and initiatives of local communities and provides risk protection to both Council and the Committee of Management.

Council acknowledges the importance of the Council/Community partnership ethic underpinning the arrangement and emphasises its commitment to supporting the valuable service provided to local communities by the various Committees of Management.

Whilst Council encourages an attitude of self-reliance by Committees of Management, it is acknowledged that due to resource limitations, the support of Council will be required from time to time in relation to funding for maintenance and improvement works beyond the financial capacity of the Committee Management.

COUNCIL RATES

Rating for Cultural & Recreational Groups will be in accordance with Council's Rating Strategy.

DATA BASE

Council will progressively develop and maintain a data base of recreational and cultural organisations for the purpose of improving communication and providing information for funding submissions etc.

DISSOLUTION OF COMMITTEES OF MANAGEMENT

In the event of the dissolution of a Committee of Management, any funds held in the name of that Committee, after payment of outstanding liabilities, will revert to the control of Council and be held in trust pending establishment of a new Committee of Management.

Council may after a period of not less than twelve months resolve to otherwise utilise such trust funds in a manner which reasonably reflects the activity source and/or geographic source of the funds.

DISBANDING OF COMMITTEES OF MANAGEMENT

In the event a Committee of Management is disbanded, no activities will be permitted on the reserve and/or facility until such time as a new Committee of Management is appointed.

COMMUNICATION

Council is committed to the maintenance of effective communication with Committees of Management.

COMPLIANCE

Appropriate monitoring of all Committees of Management operations is to be undertaken to ensure Committees comply with the terms and conditions of their agreements.

POLICY & AGREEMENTS REVIEW

Council will review this policy, the Instrument of Delegation, Licence Agreement and Tenancy Agreement on a three yearly basis unless otherwise required.



TOURISM RELATED DIRECTIONAL SIGNAGE POLICY

COUNCIL POLICY	
Effective Date:	19/09/06
Last Review:	
Current Review:	October 2013
Adopted by Council:	
Next Review Date:	
Responsible Officer	Director, Asset Services

POLICY STATEMENT

The purpose of this Policy is to establish clear principles and guidelines for to assist the management of tourist attraction, community facility and community services (ie. tourism related) directional signage within the municipality.

For the purposes of this Policy, tourism related signage is defined as directional signage under Clause 52.05 Planning Scheme - a direction sign is a sign not exceeding 0.3 square meters which directs vehicles or pedestrians. It does not include a sign that contains commercial information. Tourism related directional signage is commonly referred to as green & white or brown & white fingerboards.

This Policy provides a framework for assessing tourism related signage applications for Council Roads and for referral of applications for roads under Vic Roads' jurisdiction.

For the purposes of this Policy, applications from horse studs for Council roads will be processed in the same manner as an application for a community facility or community service. However it is worth noting that currently neither Vic Roads nor Tourism Victoria recognise these operations as either a Tourist Attraction or Community Facility / Service therefore signage applications can only be considered on Council roads.

INTRODUCTION

Applications for tourism related directional signage are to be processed by Council's Tourism and Economic Development Group, in conjunction with the Asset Services Directorate.

Approved Applicants are to be issued with a Sign Permit (attached), however, the Applicant must agree to, and comply with, all the specified terms and conditions, sign and date the Sign Permit, and return it to Council - in order to validate the approval.

The design and manufacture of approved signage may be organised by the Applicant (in accordance with specific sign design criteria), however, the installation of approved signage may only be carried out by Council or a Contractor approved by Council.

The removal of signage is to be co-ordinated by Council's Compliance Group, when it has been illegally installed.

POLICY APPLICATION

The Strathbogie Shire Council is committed to:

- Ensuring a consistent standard in roadside signage design, manufacture, installation and placement throughout the municipality; which provides an efficient information delivery system that is able to meet the needs of the travelling public, and which is consistent with other signage throughout Victoria and Australia.
- Ensuring that applications are assessed according to the "Guidelines for Tourist and Services Signing on Roads in Victoria" (*produced by Tourism Victoria and VicRoads*), specific Council and VicRoads requirements, relevant Australian Standards for roadside signage, and any relevant State and Commonwealth legislation.

- Ensuring that where an Applicant is not a tourist attraction, community facility or community service, and does not meet the “Guidelines for Tourist and Services Signing on Roads in Victoria”; that the Applicant does not qualify for directional roadside signage. Council may grant approval under exceptional circumstances to non-qualifying commercial enterprises, however, a community facility or service aspect would need to be demonstrated. Council may also consider an application for aggregated commercial signage for a business or industrial precinct.
- Recognising that the sole purpose of tourism related directional signage is to indicate direction to the travelling public; and is not to act as a substitute for other marketing and promotional activities which should be undertaken by individual establishments.
- Ensuring that restraint is applied (in the assessment of applications) in order to prevent a proliferation of signage, which has been demonstrated to reduce motorist comprehension, reduce road safety and detract from the natural beauty and amenity of the area.
- Limiting the total number of tourism related directional signs to a maximum of six (6) signs on Council controlled reserves, for each individual establishment.
- Ensuring (where practicable) that all tourism related directional signage is current and relevant, this includes limiting signage approvals to a maximum of five (5) years, after which time a review may be undertaken.
- Ensuring that only approved directional signage is installed on any Council controlled reserves; this includes the non-processing of applications where the Applicant has not removed other non-conforming and/or non-approved signage.
- Ensuring that Applicants are required to pay all costs associated with the design, manufacture and installation of approved signage; in addition to any ongoing maintenance costs, including cleaning, damage or vandalism, loss of reflectivity, replacement, reinstatement and/or re-installation.
- Ensuring safe work practices, and accordingly, only Council or Council approved Contractors are eligible to install or maintain signs on Council controlled reserves. Any such Contractors shall hold adequate public liability insurance cover and have appropriate integrated management systems.
- The Strathbogrie Shire Council may remove any tourism related directional signage, after prior notification, and without compensation, at anytime. However, consideration may also be given to the removal of signage under the following circumstances:
 - The individual business establishment has closed or no longer operates as an eligible tourist attraction, facility or service.
 - The signage is an aggregated sign, displaying the names of several business establishments, and one or more of the business establishments has closed or no longer operates as an eligible tourist attraction, facility or service.
 - The signage is in a poor state of repair and/or has become a road safety hazard.
 - Council has identified a need to reduce a proliferation of signage in the area.

The Strathbogie Shire Council may remove non-conforming and/or non-approved signage after prior notification and without compensation, at any time, particularly when:

- The signage has been installed on land under the control of Council without Council approval.
- The signage does not conform to the requirements of the “Guidelines for Tourist and Services Signing on Roads in Victoria” (*produced by Tourism Victoria and VicRoads*), specific Council and VicRoads requirements, relevant Australian Standards for roadside signage, and any relevant State and Commonwealth legislation.
- Non-conforming and/or non-approved signage will be removed as soon as practicable.
- The “owners” of the sign and/or the relevant business, are liable for all costs associated with the removal of any non-conforming and/or non-approved signage. However, Council may elect not to pursue cost recovery, if special circumstances exist.
- The “owners” of the sign and/or the relevant business have 14 days (from the date of removal) to collect any removed signage from Council’s temporary holding areas/depots. Any signage not claimed and removed within this time period, will be disposed of by Council, and any costs associated with the disposal will be recovered from the “owners” of the sign and/or the relevant business.

5.7.9 Council Policies **Review of Waste Management Policies**

Author & Department

Waste Engineer / Projects and Works Department

Disclosure of Conflicts of Interest in relation to advice provided in this report

The author of this report and officers/contractors providing advice in relation to this report do not have a direct or indirect interest, as provided in accordance with the Local Government Act 1989.

Summary

This report outlines the outcomes of a review of the existing suite of Council policies relating to waste management services. Four revised policies have been developed for Council's consideration and adoption.

RECOMMENDATION

1. That Council revoke all existing waste management policies as follows:
 - A.S.1 - Urban Residential Garbage Collections Policy
 - A.S.2 - Existing Rural Garbage Routes Policy
 - A.S.3 - Extension of Existing Rural Garbage Collection Routes Policy
 - A.S.4 – Kerbside Recycling Collection Policy
 - A.S.5 – Urban Commercial Garbage Collection Policy
 - A.S.6 - Recycling Arrangements for Non-Rateable Properties Policy (Social and Sporting Clubs, Health, Religious and Educational Organisations Within Urban Townships)
 - A.S.7 - Disposal of Recyclables at Council's Waste Collection Sites Policy.
2. That Council adopts the following new policies:
 - Household Garbage and Recycling Collection Services Policy
 - Commercial Garbage and Recycling Collection Policy
 - Recycling Arrangements for Educational Institutions Policy
 - Waste Management Arrangements for Rateable and Non-Rateable Public User Groups Within Urban Townships Policy

Background

A total of eight (8) policies relating to Council's waste management services currently exist. These existing policies were developed in 1998 and 2001, with all eight being last reviewed in 2003. As a result, a number of the policies and a number of clauses within some policies are no longer relevant.

5.7.9 Council Policies
Review of Waste Management Policies (cont.)

Officers conducted a review of these eight policies in September 2013. This review resulted in the withdrawal of five of the existing policies, four of which have been combined into one new policy and the fifth has been revoked altogether.

The remaining three policies have been renamed and amended to better reflect the current services being delivered. In total, this has led to a decrease in the total number of policies from eight to four.

A summary of the existing policies, the outcomes of the latest review and any notable changes made to the existing policies is provided in the table below:

EXISTING POLICY	RESULTS OF REVIEW	NOTEABLE CHANGES
A.S.1 – Urban Residential Garbage Collections Policy	Existing policy has been revoked. Relevant clauses retained and incorporated into new policy named “Household Garbage and Recycling Collection Services Policy”	<ul style="list-style-type: none"> • Introduced the requirement for all garbage services to be matched with at least the equivalent number of recycling services • Introduced the ability for large households to replace their 120 litre garbage bin for a 240 litre bin at no extra cost.
A.S.2 – Existing Rural Garbage Routes Policy	Existing policy has been revoked. Relevant clauses retained and incorporated into new “Household Garbage and Recycling Collection Services Policy”	<ul style="list-style-type: none"> • Still an optional service for rural properties, however the requirement to have to retain the service forever has been removed.
A.S.3 – Extension of Existing Rural Garbage Collection Routes Policy	Existing policy has been revoked. Relevant clauses retained and incorporated into new “Household Garbage and Recycling Collection Services Policy”	Nil
A.S.4 - Kerbside Recycling Collection Policy	Existing policy has been revoked. Relevant clauses retained and incorporated into new “Household Garbage and Recycling Collection Services Policy”	<ul style="list-style-type: none"> • Collection services now offered to rural areas
A.S.5 – Urban Commercial Garbage Collection Policy	Existing policy has been revoked. Relevant clauses retained and policy renamed as “Commercial Garbage and Recycling Collection Policy”	<ul style="list-style-type: none"> • Inclusion of recycling collection service • Information on compulsory service charges for township / residential zones added to document.

5.7.9 Council Policies
Review of Waste Management Policies (cont.)

EXISTING POLICY	RESULTS OF REVIEW	NOTEABLE CHANGES
A.S.6 – Recycling Arrangements for Non-Rateable Properties Policy (Social and Sporting Clubs, Health, Religious and Educational Organisations Within Urban Townships)	Existing policy has been revoked. Policy amended to cover only Educational Institutions and renamed “Recycling Arrangements for Educational Institutions Policy”	<ul style="list-style-type: none"> • Exclusion of Social and Sporting Clubs and Health and Religious Organisations (covered in other policies) • Provision of additional recycling services as incentive for schools to participate in the ResourceSmart AuSSi Vic Program.
A.S.7 – Disposal of Recyclables at Council’s Waste Collection Sites Policy	Existing policy has been revoked. No longer relevant with improved recycling infrastructure at transfer stations and collection points.	<ul style="list-style-type: none"> • Policy removed
A.S.8 – Waste Management Arrangements for Rateable and Non-Rateable Public User Groups Within Urban Townships, Including Social, Sporting and Other Interest Groups Policy	Existing policy revoked. Relevant clauses retained and policy renamed “Waste Management Arrangements for Rateable and Non-Rateable Public User Groups Within Urban Townships Policy”	<ul style="list-style-type: none"> • Inclusion of 240 litre recycling collection services to all groups • Introduced the requirement for all garbage services to be matched with at least the equivalent number of recycling services. • Incorporated a clause relating to the supply and empty of bins for “Special Events”

Alternative Options

The author and other officers providing advice in relation to this report have considered potential alternative courses of action. No feasible alternatives have been identified.

Risk Management

The author of this report considers that there are no significant Risk Management factors relating to the report and recommendation

Strategic Links – policy implications and relevance to Council Plan

The author of this report considers that the policies being put forward provide incentive to minimise the amount of waste within the municipality that is being sent to landfill. This is in line with the Council Plan Objective *“To continue to protect and enhance the natural and built environment for current and future generations.”*

5.7.9 Council Policies
Review of Waste Management Policies (cont.)

Whilst these policies adequately reflect council's current waste services, there is certainly scope to be able to incorporate any new services into the policies if and when they are introduced.

Best Value / National Competition Policy (NCP / Trade Practices Act (TPA) implications

The author of this report considers that the report is consistent with Best Value, National Competition Policy and Trade Practices Act requirements.

Financial / Budgetary Implications

The author of this report considers that the recommendation has no capital or recurrent budget considerations.

Economic Implications

The author of this report considers that the recommendation has no significant economic implications for Council or the broader community.

Environmental / Amenity Implications

The author of this report considers that the policies being put forward provide incentive to minimise the amount of waste within the municipality that is being sent to landfill.

Community Implications

In addition to enhancing the structure around Council's waste services, the policies being put forward provide Council, residents, ratepayers and community groups with adequate information in relation to roles and responsibilities.

Victorian Charter of Human Rights and Responsibilities Act 2006

The author of this report considers that the recommendation does not limit any human rights under the Victorian Charter of Human Rights and Responsibilities Act 2006.

Legal / Statutory Implications

The author of this report considers that the recommendation has no legal or statutory implications which require the consideration of Council.

Consultation

In order to ensure all policies aligned with current procedures and practices, consultation was carried out with Council's Revenue Coordinator and Council's Waste Services Contractor before finalising.

It was considered that consultation with the broader community was not warranted.

Attachments

Copies of the four new policies are attached to this report.



HOUSEHOLD GARBAGE AND RECYCLING COLLECTION SERVICES POLICY

COUNCIL POLICY

Effective Date:	
Last Review:	
Current Review:	September 2013
Adopted By Council:	
Next Review Date:	Annually/Bi-Annually/As required
Responsible Officer/s:	Director, Asset Services

POLICY STATEMENT

The purpose of this Policy is to state Council's objective with regard to kerbside garbage and recycling collections to households within the Shire.

POLICY APPLICATION

This Policy applies to the garbage and recycling collection services provided by Council and their associated service charges.

POLICY

1. Statement of Commitment

The Strathbogie Shire Council is committed to the following goals

- Minimising the amount of waste sent to landfill
- Providing economical and efficient kerbside garbage and recycling services to as many residents in the municipality as possible.

2. Service Charges

- a) Council will consider declaring garbage and recycling service charges and their quantum during the budget process each year.
- b) A service charge is an annual charge on a property
- c) Each annual charge will be per collection service (one Mobile Garbage Bin (MGB))

3. About the Services

- a) The services provided will be delivered as follows:
 - Garbage 120 litre MGB collected weekly*
 - Recycling 240 litre MGB collected fortnightly
- b) All properties receiving garbage collection services MUST also receive at least the equivalent number of recycling collection services.
- c) All MGB's provided to residents remain the property of Council and must be kept at the address they have been issued to.
- d) The cost of replacement of a damaged or stolen MGB may be sought from the ratepayer of the property the MGB was allocated to.
- e) Given the large geographic size of the municipality, it is not economically feasible to support a collection service to all areas of low density settlement. As such, collection routes are mainly limited to:
 - Township Zones
 - Rural areas where the ratio of homes to the distance travelled makes provision of a service economically feasible; and
 - Roads travelled that link collection routes together.

** For residential properties with 6 or more people permanently residing, this may be replaced with a larger 240 litre bin at no extra cost, at the request of the resident. Residents are required to present their Medicare Card as proof that 6 or more residents are living at the premises. Residents with medical conditions that result in larger than usual waste generation are able to obtain a larger 240 litre bin or an extra 120 litre bin to adequately deal with the additional waste.*

4. Kerbside Collection Services in Urban Areas

- a) One Garbage Service Charge and one Recycling Service Charge will be levied on all habitable dwellings within township zones and designated densely populated areas of the municipality. These charges will apply regardless of whether or not:
 - the dwelling is permanently occupied or
 - the service is required or utilised.
- b) Charges for services on new dwellings in urban areas shall apply as of the date that Council's Rates Department receive the Certificate of Occupancy.
- c) Application can be made by the property owner or person legally responsible for payment of rates, to receive additional collection services from a property.
- d) Each additional garbage collection service must be matched with the equivalent number of recycling collection services. However, application can be made for additional recycling collection services alone.

5. Kerbside Collection Services in Rural Areas

- a) Collection services are available on application to all habitable dwellings located on existing collection routes. Application must be made by the property owner or person legally responsible for payment of rates.
- b) Collection services may be available for properties adjacent to existing collection routes, provided the MGB's are delivered to and from an agreed location on the route and any other criteria stipulated by Council and / or its service provider is met.
- c) Each garbage collection service must be matched with the equivalent number of recycling collection services. However, application can be made for additional recycling collection services alone.

Extensions to Collection Routes.

- a) Existing collection routes will only be extended providing the following criteria are met:
- Economic feasibility of additional service (cost –v- benefit);
 - Contractual arrangements;
 - Physical restraints on extended route;
 - Number and proximity of dwellings serviced;
 - Proximity to existing collection area;
 - Impact of additional route on collection day program;
 - At least 75% of property owners who own a habitable dwelling on the proposed route provide written agreement to receive the proposed services.
- b) In addition, Council could, at its discretion, choose to extend collection routes based on, but not limited to, the following:
- Township growth
 - Contractor's collection schedules



COMMERCIAL GARBAGE AND RECYCLING COLLECTION POLICY

COUNCIL POLICY

Effective Date:	20/10/1998
Last Review:	18/02/2013
Current Review:	September 2013
Adopted By Council:	
Next Review Date:	Annually/Bi-Annually/As required
Responsible Officer/s:	Director, Asset Services

POLICY STATEMENT

The purpose of this Policy is to state Council's objectives on the collection of garbage and recycling from commercial premises.

POLICY APPLICATION

This Policy applies to the garbage and recycling collection services provided by Council and their associated service charges.

POLICY

1. Statement of Commitment

Strathbogie Shire Council is committed to the goal of ensuring commercially rated properties within the Shire have access to economical and effective garbage and recycling collection services where feasible.

2. Service Charges

- d) Council will consider declaring commercial garbage and recycling service charges and their quantum during the budget process each year.
- e) A commercial service charge is an annual charge on a property
- f) Each annual commercial service charge will be per collection service (one Mobile Garbage Bin (MGB)).
- g) One Garbage Service Charge and one Recycling Service Charge will be levied on all commercial premises within township zones and designated densely populated areas of the municipality.

Owners / operators of such premises can have these service charges waived, provided they can arrange an alternative means of disposing of garbage and recycling that meets the satisfaction of Council's Waste Services Contract Supervisor.

3. Collection Options Available to Commercial Premises

- a) Owners / operators of commercial premises may choose one of two options regarding waste and recycling collection.

Option 1:-

Commercial premises can receive garbage and recycling collection services from Council, provided that the waste being disposed of is the same type as that generated by a domestic property.

Premises may have multiple numbers of MGBs, however the relevant service charge will apply for each bin.

Commercial operators may choose from the following Council services:

- Garbage -
 - i. 120 litre MGB collected weekly and charged at the standard annual residential garbage service rate.
 - ii. 240 litre MGB collected weekly and charged at the standard annual commercial garbage service rate.

- Recycling -
 - i. 240 litre MGB collected fortnightly and charged at the standard annual residential recycling service rate.

Option 2:-

Owners / operators of commercial premises can arrange and finance private garbage collection and private recycling collection services. Council's service charges will not be applied to premises choosing this option.

4. Part Commercial / Part Residential Premises

- a) For premises in urban areas that are combined residential / commercial, one residential garbage and one residential recycling service charge will be levied on the residential part of the premise.

Should additional services be required for the commercial part of the premise, owners / operators can choose to arrange services as per the two options outlined in Clause 2a).



RECYCLING ARRANGEMENTS FOR EDUCATIONAL INSTITUTIONS POLICY

COUNCIL POLICY

Effective Date:	
Last Review:	
Current Review:	September 2013
Adopted By Council:	
Next Review Date:	Annually/Bi-Annually/As required
Responsible Officer/s:	Director, Asset Services

POLICY STATEMENT

The purpose of this Policy is to state Council's objectives to assist with and promote recycling at educational institutions such as:

- Schools,
- Kindergartens,
- School Camps,
- Outdoor Education Facilities.

POLICY APPLICATION

This Policy provides guidance in the provision of recycling collection services to educational institutions within the municipality.

POLICY

1. Statement of Commitment

The Strathbogrie Shire Council is committed to the goal of encouraging recycling at educational institutions to assist with educating students in the benefits of diverting waste from landfill.

2. Proportional allocation of recycling services.

All educational institutions will receive recycling service allocations based proportionally on the number of students enrolled, at a rate of one service per 100 students. These allocations will be provided free of charge by Council.

0 - 100 Students = 1 x 240 litre mobile recycling bin.

Increments of 100 increase in student numbers will receive one extra bin per increment.

Educational institutions requesting additional recycling services shall apply to Council in writing. Each additional service shall be subject to the standard Recycling Service Charge.

3. ResourceSmart - Australian Sustainable Schools Initiative Victoria (AuSSI Vic)

ResourceSmart AuSSI Vic is a statewide program which provides practical support to schools and their communities to learn to live and work more sustainably.

Council will provide additional recycling services free of charge to those educational institutions that commit to the ResourceSmart AuSSI Vic program, provided the institution has:

- successfully completed the ResourceSmart AuSSI Vic program's Core Module and
- commenced the ResourceSmart AuSSI Vic program's Waste Module and
- determined that additional recycling services over and above their available proportional allocation are required to successfully complete the Waste Module.



WASTE MANAGMENT ARRANGEMENTS FOR RATEABLE AND NON- RATEABLE PUBLIC USER GROUPS WITHIN URBAN TOWNSHIPS POLICY

COUNCIL POLICY

Effective Date:	
Last Review:	
Current Review:	September 2013
Adopted By Council:	
Next Review Date:	Annually/Bi-Annually/As required
Responsible Officer/s:	Director, Asset Services

POLICY STATEMENT

The purpose of this policy is to provide a fair and consistent approach to waste management arrangements for Rateable and Non-rateable Public User Groups within Urban Townships.

This includes Social, Sporting, and other interest Groups.

POLICY APPLICATION

This policy applies to the garbage and recycling collection services and their associated service charges, provided by Council to public user groups.

POLICY

1. Statement of Commitment

The Strathbogie Shire Council is committed to the goal of waste minimisation for public user groups. This will be achieved by the provision of a consistent service, encouraging responsible attitudes towards reducing volumes of waste generated and promoting initiatives in recycling.

2. Proportional allocation of waste and recycling facilities

Community Groups will receive collection service allocations based proportionally on the Township's population and / or membership, based on the user group type.

These service allocations will be provided free of charge by council, provided an undertaking in writing is made and acted upon by the group to initiate, promote, and action positive recycling procedures.

If a group does not provide this written undertaking, or fails to act upon this undertaking, then the group will forfeit their free allocation of services provided by Council.

3. Additional collection services.

Additional collection services required over and above a group's prescribed allocation will be subject to the appropriate service charges. This includes additional 'one off' services required for 'Special Events' (refer to clause 5)

Each additional garbage service **MUST** be matched with at least the equivalent number of recycling services.

4. Green waste disposal

In general, an undertaking is required by user groups to initiate, promote, and action, the management of organic waste matter in a responsible manner at the user group site.

In the case of green waste generated in the maintenance of a Council owned property, it will be accepted free of charge at the local transfer station, provided a prior arrangement is made with the Council's waste services contract supervisor.

5. Special Events

Organisers of special events within the shire can apply to Council for the provision of garbage and recycling services for their event.

Application must be made to Council at least:

- 14 days in advance of the event date for events requiring less than 10 bins or;
- 28 days in advance of the event date for events requiring more than 10 bins

Garbage collection services required for special events will be subject to the appropriate garbage service rate for special events, as specified in Council's waste services contract of the time.

Council will provide up to five (5) recycling collection services free of charge for special events, provided an undertaking in writing is made and acted upon by the event organiser to initiate, promote, and action positive recycling procedures.

6. Placement of bins for collection

Bins will be placed out for collection by user groups / event organisers on the roadside adjacent to the user group's facility / event venue on appropriate days, as per normal household collections.

This will be the standard arrangement unless an alternative, suitable collection arrangement is agreed to by Council's waste services contract supervisor.

7. Exclusions

- a) This policy does not apply to those user groups / events whose needs do not justify a collection service. Justification will be determined by Council's waste services contract supervisor, taking into consideration
 - waste volumes,
 - site access and
 - bin security.
- b) This policy does not apply to those user groups / events that are located in an area remote from existing collection routes.

8. Definition of user groups and bin allocations

a) 'A' Groups; Recreational Reserves with multi-use facilities

Recreation reserves which include joint user groups (such as Football, Cricket, Netball and Tennis Clubs) will receive collection service allocations based proportionally on the Township's population, at a rate of one 240 litre garbage bin and one 240 litre recycling bin per 500 head of population.

These services will be provided free of charge, provided an undertaking in writing is made and acted upon by the group to initiate, promote, and action, waste reduction and positive recycling procedures.

0 - 500 Population = 1 x 240 litre mobile garbage bin (MGB) and
1 x 240 litre mobile recycling bin (MRB)*
**(or alternatively 2 x 120 litre MGBs and / or 2 x 120 litre MRBs)*

Increments of 500 increase in population will receive an extra garbage and recycling bin per increment.

b) 'B' Groups; Sporting Clubs (including Bowls, Tennis, Golf).

Groups such as, individual Bowls, Golf and Tennis Clubs will receive collection service allocations based proportionally on their Membership.

These will be provided free of charge provided an undertaking in writing is made and acted upon by the group to initiate, promote, and action, waste reduction and positive recycling procedures.

0 - 120 Members = 1 x 120 litre MGB and 1 x 240 litre MRB.
120+ Members = 1 x 240 litre MGB** and 2 x 240 litre MRB**.
*** (or alternatively 2 x 120 litre MGBs)*

c) 'C' Groups; Senior Citizens and RSL Clubs

Senior Citizens and RSL Clubs will receive collection service allocations based proportionally on the Township's population.

These will be provided free of charge provided an undertaking in writing is made and acted upon by the group to initiate, promote, and action, waste reduction and positive recycling procedures.

0 -1000 Population = 1 x 120 litre MGB and 1 x 120 litre MRB
1000+ Population = 1 x 240 litre MGB and 1 x 240litre MRB***
**** (or alternatively 2 x 120 litre MGBs and / or 2 x 120 MRBs)*

d) 'D' Groups; Community Halls

Community Halls will receive one 120 litre MGB and one 240 litre MRB.

These will be provided free of charge provided an undertaking in writing is made and acted upon by the group to initiate, promote, and action, waste reduction and positive recycling procedures.

e) 'E' Groups; Cemeteries

Cemeteries will receive collection service allocations based proportionally on the Township's population.

These will be provided free of charge, provided an undertaking in writing is made and acted upon by the group to initiate, promote, and action, waste reduction, positive recycling procedures, manage organic waste matter in a responsible manner.

0 - 1500 Population = 1 x 120 litre MGB and 1 x 120 litre MRB

1500+ Population = 1 x 240 litre MGB and 1 x 240 litre MRB****

****(or alternatively 2 x 120 litre MGBs and / or 2 x 120 litre MRBs).

9. Appendix

Populations based on last census taken in 2011

- Avenel 1048
- Euroa 3167
- Longwood 416.
- Nagambie 1548
- Strathbogie 309
- Violet Town 1084

5.7.10 Documents for Signing and Sealing

Documents are submitted for Council signing and sealing.

The details are as follows and are also included in Council's Seal Register:-

FILE NO.	DOCUMENT DESCRIPTION	NO. OF COPIES
Contract No. 13/14-01	Deed of Agreement between Strathbogie Shire Council and Statewide Pool Services Pty Ltd for Sand Filter Upgrade Euroa Outdoor Swimming Pool	2

RECOMMENDATION

That the Documents be signed and affixed with the Common Seal of Strathbogie Shire Council.

THERE BEING NO FURTHER BUSINESS, THE MEETING CLOSED AT P.M.